



PVC & SUPPORT EQUIPMENT
PVC & DESTEK EKİPMANLARI

We Always Provide Reliability

Manufacturing is complicated but it is much more difficulty to provide simultaneously production and appropriate reliability. We carry out the most complicated process. Because since 1977 reliability, technology, durability, aesthetic, sensitivity and conformity are incorporated and have found in their reflection in all our production.

Her Zaman Güven Ürettik

Üretmek zordur, ürettiklerinle güveni aynı potada eritmek daha da zor. Biz dünyanın en zor işini yapıyoruz. Çünkü 1977'den beri güveni; teknoloji, dayanıklılık, estetik, hassasiyet ve uyumla birleştirerek tüm ürünlerimize yansıtıyoruz.



MACHINING CUTTING & CLEANING CENTERS İŞLEME KESİM & ÇAPAK ALMA MERKEZLERİ

PIM 6509	6-9
CCL 1661	10-13

CUTTING KESİM

KD 402 S	16-17
DC 421 PSD	18-19
DC 421 PBS	20-21
ACK 420 S	22-23
MK 420 - 420 PS - 450	24-25
RYK 420 W	26-27
SCM 420 L4 - 420 L7	28-29
CK 412	30-31
SDT 280	32-33
SDT 275	34-35
KD 400 D - 400 PS	36-37
KD 400 M	38-39
KD 350 D - 350 PS	40-41
KD 350 M	42-43

END MILLING & COPY ROUTING KERTME & FREZELER

KM 215 S	46-47
KM 212	48-49
KM 211 S	50-51
FR 226 S	52-53
FR 223 - 223 S	54-55
FR 222	56-57
FR 221 S	58-59
ST 264	60-61
CRM 250 S	62-63
CRM 201 S	64-65
NCR 300	66-67

WELDING & CLEANING KAYNAK & ÇAPAK ALMA MAKİNELERİ

TK 505	70-71
TK 503	72-73
DK 540	74-75
DK 502	76-77
CA 603	78-79
CA 601	80-81
CNC 609 - 611	82-83
WGM 202	84-85

SCREWDRIVING DESTEK SACI VİDALAMA

SM 206	88-89
SM 201	90-91
SM 201 SD	92-93
MCA 801	94-95

SUPPORT EQUIPMENT DESTEK EKİPMANLARI

VCE 1570 / GAS 301	98-99
HDL 400 - 700	100-101
DKN 302 - 602 / MKN 150 - 300 - 301	102-103
SKN 300 - 600 - 301	104-105
NSM 352 - 353	106-107
WB 4000 - PWB 4100 - GPT 1000 - PT 1000	108-109
HP 1000 - VP 1000 - GT 1000 - RT 1000	110-111
PC 4000 - PT 2000 - VP 2000 - WAS 1000	112-113
RS 1000	114

MACHINE COMPARISON TABLES MAKİNE KARŞILAŞTIRMA TABLOLARI

WORKSHOP LAYOUTS ATÖLYE PLANLARI	123-131
---	---------

MACHINING, CUTTING AND CLEANING CENTERS

*İŞLEME, KESİM VE ÇAPAK ALMA
MERKEZLERİ*



PIM 6509

PVC PROFILE MACHINING AND CUTTING CENTER
PVC PROFİL İŞLEME VE KESME MERKEZİ

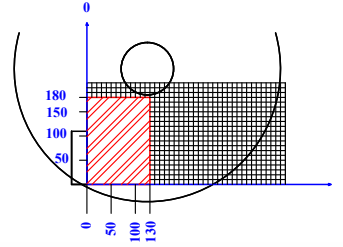

90°: 130 mm x 180 mm

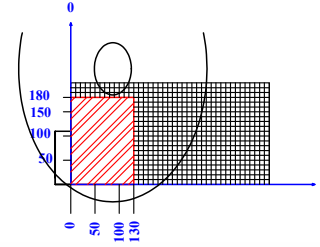

45°: 130 mm x 180 mm

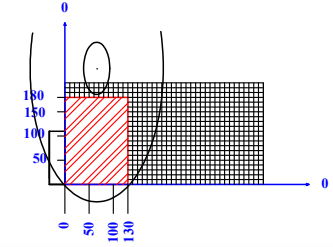





60°: 130 mm x 180 mm

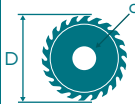

Angled swarf conveyor
Açılı talaş konveyörü



						
			Bar	Air Cons.		
14 kW 40A 400V AC 3P PE 50-60 Hz,	D: Ø550 mm d: Ø30 mm 2.440 RPM	18.000 RPM	6-8	250 L/min.	280x1.344x231	3.650 4.106

GENERAL FEATURES

- Servo control system providing CNC motion at 8-axis
- Fully automated feeding, carrying, positioning, cutting and transferring units
- Performing operations on four sides of PVC profiles such as milling, opening key holes, water slots, hinge holes, handle holes, marking, saw blade cutting etc.
- Pneumatic gripper for accurate positioning of the profile moving in three axes
- Horizontal and vertical clamping of workpiece during the sawing operation
- Profile processing capacity with 2.200 - 2.400 running meter / 8 hours
- Automatic conveyor unit with the loading capacity of 7 pcs of profiles
- Servo controlled down-cutting saw blade with Ø550 mm dia. that rotates between the range of 30° and 150°
- Windows based PC and 15.6" LCD touch screen monitor
- Simultaneous optimization on the machine allows the machine to optimize itself on the waste profiles
- Remote desktop connection and providing technical support
- User friendly interface software that is compatible with CAD programs
- Ability to perform milling and cutting operations at the same time
- Easy integration with the CNC welding, corner cleaning and crewing machines
- Automatic frame and sash profile recognition system
- Automatic profile width and height dimension control system
- Automatic lubrication system
- Low pressure control for saw blade safety operations
- LED Interior lighting

STANDARD ACCESSORIES

- Total of 11 tools, consisting of milling and drilling cutters
- Safety fence around the machine
- Keyboard & mouse
- Barcode printer

OPTIONAL ACCESSORIES

- Workshop logistic equipment (see the tech. document)
- Spare cutter bits (see the tech. document)
- KP 3500 chip vacuum extractor
- Spare Ø550 mm saw blade
- Angled swarf conveyor

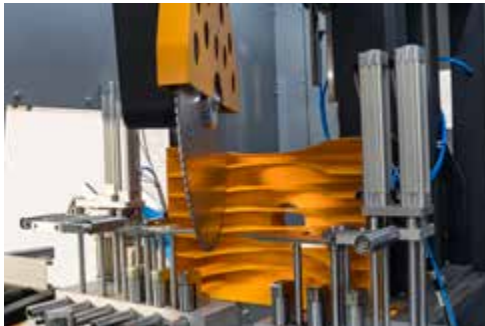

GENEL ÖZELLİKLER

- 8 eksenle hareket sağlayan CNC kontrol sistemi
- Otomatik besleme, taşıma, pozisyonlama, kesme ve aktarma özelliği
- PVC profillerin dört yüzeyinde frezeleme, su tahliye kanallarının, menteşe, anahtar ve kol deliklerinin açılması ile testere ile boy kesme operasyonlarını yapabilmek
- Profillerin hassas olarak pozisyonlanmasını sağlayan pnömatik tutucu ünite
- Otomatik olarak çalışan yatay ve dikey mengene sistemi
- 2.200-2.400 m.tül / 8 saat profil işleme kapasitesi
- 7 adet profil kapasiteli otomatik besleme konveyörü
- Ø550 mm çaplı servo kontrollü testere ile 30° ve 150° derece arasında hassas kesim
- Windows tabanlı PC ve 15.6" dokunmatik panel ekran
- Makine üzerinde simultane olarak yapılan optimizasyon sayesinde
- makine fire profilleri üzerinde kendisi optimizasyon yapabilir
- Uzaktan bağlanma ve teknik destek sağlama
- Kolay kullanılabilen ve bütün çizim programlarına entegre ara yüz program
- Frezeleme ve kesme işlemlerini aynı anda yapabilmek
- Dört köşe PVC kaynak temizleme ve vidalama hattına entegrasyon
- Otomatik kasa ve kanat profillerini tanıma sistemi
- Otomatik profil genişlik ve yükseklik ölçülerini kontrol sistemi
- Otomatik yağlama sistemi
- Testere düşük basınç emniyet kontrolü
- Kabin içi çok düşük enerji tüketimi olan LED aydınlatma

STANDART AKSESUARLAR

- Toplam 11 adet freze takılı olarak
- Makine etrafına güvenlik çiti
- Klavye & mouse
- Barkod yazıcı

OPSİYONEL AKSESUARLAR

- Atölye lojistik ekipmanları (teknik dokümana bkz.)
- Yedek kesici takımlar (teknik dokümana bkz.)
- KP 3500 talaş emici aspiratör
- Yedek Ø550 mm testere
- Açılı talaş konveyörü

PIM 6509 - Technical Table

AXIS	
Total axis	8
Max. profile length (mm)	6.500
Min. profile length (mm)	700
POSITIONING SPEED	
Axis speed (m/min.)	X: 40 / Y: 40 / Z: 40
U-axis profile infeed speed (m/min.)	100
AUTOMATIC CUTTING MODULE	
Saw blade dia. (mm)	550
Min cutting length at (45° and 90°) (mm)	400
Saw blade cutting range (°)	from 30° to 150°
Power of sawing motor (kW)	2.2
AUTOMATIC MILLING	
Total milling motor	10
Triple hole motor	1
Min. machinable profile dim. (mm) (WxH)	40x40
Max. machinable profile dim. (mm) (WxH)	130x180
FUNCTIONS	
Multi-piece operations such as milling, opening key holes, water slots, hinge holes, handle holes, marking, saw blade cutting etc.	yes
GENERAL	
Net and gross weight (kg)	3.650 x 4.106
Net dim. (mm) (WxLxH)	2.790 x 13.440 x 2.310
Packing Dim. (mm)	1pc.466x 84x227 1pc.44x184x144 1pc.296x141x132 1pc.224x230x244 1pc.178x178x52
Voltage - frequency	400V AC 3P PE 50/60 Hz
Total power	14 kW 40A

EKSEN HAREKETİ	
Toplam eksen	8
Maksimum profil boyu (mm)	6.500
Minimum profil boyu (mm)	700
POZİSYONLAMA HIZI	
İşleme ünitesi eksen hızları (m/dk.)	X: 40 / Y: 40 / Z: 40
U-Eksen profil besleme hızı (m/dk.)	100
OTOMATİK KESME ÜNİTESİ	
Testere çapı (mm)	550
90° ve 45°de minimum kesme boyu (mm)	400
Testere bıçağı kesme aralığı (°)	from 30° to 150°
Testere motoru kapasitesi (kW)	2.2
OTOMATİK FREZELEME ÜNİTESİ	
Toplam frezeleme motoru	10
Üçlü kol yeri delme Ünitesi	1
Minimum işlenebilir profil ölçüsü (mm) (WxH)	40x40
Maksimum işlenebilir profil ölçüsü mm) (WxH)	130x180
OPERASYONLAR	
PVC profillerde çok yönlü operasyonlar (su tahliye kanalı açma, kapı kolu, barel, kilit ve menteşe deliği açma vb.)	evet
GENEL	
Net / brüt ağırlık (kg)	3.650 x 4.106
Net ölçüleri (mm) (WxLxH)	2.790 x 13.440 x 2.310
Ambalajlı ölçü (mm)	1ad.466x184x227 1ad.44x184x144 1ad.296x141x132 1ad.224x230x244 1ad.178x178x52
Voltaj - frekans	400V AC 3P PE 50/60 Hz
Toplam Güç	14 kW 40A

CCL 1661

PVC WELDING AND CORNER CLEANING LINE
PVC KAYNAK VE KÖŞE TEMİZLEME HATTI

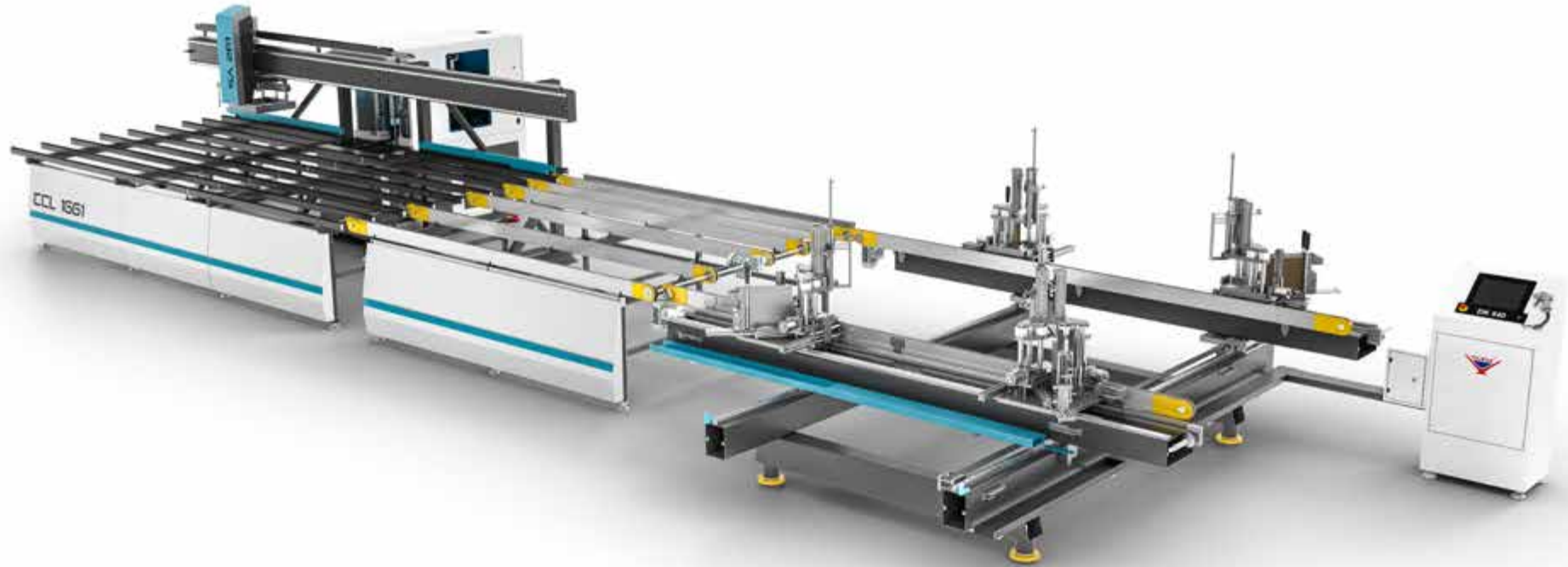

					Bar	Air Cons.		
12 kW 400V AC 3P PE 50-60 Hz,	Wmin: 400 mm Lmin: 400 mm Wmax: 2.200 mm Lmax: 2.200 mm	Hmax: 180 mm Hmin: 30 mm Wmax: 130 mm Wmin: 30 mm	D:Ø250 mm d:Ø30-32 mm 6.000 RPM	18.000 RPM	6-8	150 L/min.	2.472x11.725x207	3.776
								3.931

GENERAL FEATURES

- Yılmaz custom profiles cleaning program
- Manuel and automatic operating modes
- Automatic sash and frame profile recognition system
- Profile width and height measurement system
- 11 set of automatic profile cleaning knives
- Separate cleaning knives for color and white profiles
- Automatic central lubrication system
- Window based touch screen
- Profile program transfer via USB flash memory
- Remote connection and technical support capability
- Movable control panel
- Speed change during the process
- 220 frames / 8 hours (609 CNC) and 270 frames / 8 hours (CNC 611) machining capacity
- Visible of screen alarms and warnings
- Phase control system
- Low pressure control system
- Ability of cleaning all four corners and end-of-line transfer with automatic profile rotation robot system
- Automatic system allowing movement in 2 or 4 axis
- Automatic transition feature between 0.2 and 2.0 mm welding range, specific to Yılmaz Machine
- Automatic operation mode integrated with barcode reader or manual operation as per entered dimensions
- Lame sash door welding
- Capable of entering the welding parameters on the screen and storing them
- Fast and easy teflon replacement feature
- Ability of creating 1.000 pieces of profile recipes
- Monitoring of processing times during the operation
- Easy placement of long size profiles on the welding unit
- Milimeter or inch operation system modes
- Max square dimension that SA 261 machine can be rotated is 2.200 x 2.200 mm. The squares that are having larger dimensions are rotated manually during the welding operation

STANDARD ACCESSORIES

- DK 540 Four Head Welding Machine
- SA 251 Cooling Unit
- SA 261 Robot Unit
- CNC 609 or CNC 611 Cleaning Machine
- Total of 11 tools, consisting of a cleaning saw, internal scraping blades and milling cutters
- Brushed window support table

OPTIONAL ACCESSORIES

- CS 240 gasket pressing system
- DK 540 Welding fixture set for lame sash
- DK 540 Welding fixture set

GENEL ÖZELLİKLER

- Müşteri profillerine göre yazılmış temizleme programları
- Manuel ve otomatik olarak çalışabilme özelliği
- Otomatik kasa ve kanat profil tanıma özelliği
- Profil genişlik ve yükseklik ölçü kontrol sistemi
- 11 set otomatik profil temizleme bıçağı
- Renkli ve beyaz profiller için ayrı temizleme bıçakları
- Otomatik merkezi yağlama sistemi
- Windows tabanlı dokunmatik ekranlı bilgisayar
- USB bellek ile programı transfer edebilme
- Uzak bağlantı ile teknik destek imkanı
- Hareket ettirilebilir kontrol paneli
- Proses esnasında değiştirilebilir hız
- 220 çerçeve/8 saat (CNC 609), 270 çerçeve/8 saat (CNC 611)
- Alarm ve uyarıların ekrandan görülebilmesi
- Faz kontrol sistemi
- Düşük basınç kontrol sistemi
- Otomatik profil çevirme robotu ile 4 köşeyi temizleme hat sonuna transfer edebilme özelliği
- 3 eksenli hareket sağlayan otomasyon sistemi (X, Y, Z)
- 0,2- 2.0 mm kaynak opsiyonları için manuel ayar imkanı
- Manuel ölçü girerek veya barkod okuyucu ile otomatik çalışabilme özelliği
- Topal kapı kaynatılabilme
- Kaynak parametrelerin ekran üzerinden girilebilmesi ve kaydedilebilmesi
- Hızlı ve kolay değiştirilebilir ütü teflonu özelliği
- 1.000 adet profili reçetesi oluşturabilme
- Proses esnasında işlem sürelerini ekrandan takip edebilme
- Uzun ölçülerde kolay profil yerleştirebilme imkanı
- Milimetre veya inç çalışma sistemi
- SA 261 Otomatik Çevirme Robotunun maksimum çevirebileceği çerçeve ölçüsü: 2.200 mm x 2.200 mm. Bu ölçüden büyük profiller manuel (elle) olarak çevrilir.

STANDART AKSESUARLAR

- DK 540 Dört Köşe Kaynak Makinesi
- SA 251 Soğutma İstasyonu
- SA 261 Robot Mekanizması
- CNC 609 veya CNC 611 Çapak Alma Makinesi
- Profil temizleme testeresi, iç kazıma bıçakları ve frezelerden oluşan 11 adet takımlik set
- Fırçalı pencere destek tablası

OPSİYONEL AKSESUARLAR

- CS 240 conta baskı sistemi
- DK 540 Kaynak ağızlığı topal kasa grubu
- DK 540 talebe göre kaynak kalıpları

CCL 1661 - Technical Table

WELDING (DK 540)	
Axis speed (X/Y) (RPM)	X: 10,6 / Y: 10,6
Power of axis motor (kW)	0,37
Power of conveyor motors (kW)	0,25
Max. machinable profile height / width (mm)	H: 180 / W: 130
Min. machinable profile height / width (mm)	H: 30 / W: 30
Max. / Min. weldable frame sizes (mm)	3.100 x 2.700 / 400 x 400
CNC CLEANING (CNC 608 / CNC 610)	
Axis speed (X/Y) (m/min.)	Y: 30 / Z: 30
Power of servo motors (kW)	0,85
Power of saw blade motor (kW)	0,75
Power of milling motors (kW)	0,22
Speed of saw blade motor (RPM)	6.000
Speed of milling motors (RPM)	18.000
Number of cleaning tools	11
Max. machinable profile height / width (mm)	H: 180 / W: 130
Min. machinable profile height / width (mm)	H: 30 / W: 30
Max. / min. machinable frame sizes (mm)	2.200 x 2.200 / 400 x 400
TRANSFER ROBOT (SA 260)	
Power of transfer robot (kW)	0,85
Max. profile height / width it can grip (mm)	H: 180 / W: 130
Min. profile height / width it can grip (mm)	H: 30 / W: 30
Max. / min. frame size it can transfer (mm)	2.200 x 2.200 / 400 x 400
GENERAL	
Net / gross weight (kg)	3.776/ 3.931
Packing dimensions (cm)	1 pc x 3,35 x 0,34 x 2,3 1 pc x 3,3 x 0,34 x 2,32 1 pc x 5,7 x 0,82 x 1,12 1 pc x 1,9 x 2,04 x 1,05
Air pressure	6-8 bar
Voltage - Frequency - Current	400V AC 3P N PE 50/60 Hz.
Total Power (with CNC 608 / with CNC 610) (kW)	12 / 14

KAYNAK (DK 540)	
Eksen hızları (X/Y) (m/dk.)	X: 10,6 / Y: 10,6
Güç eksen motorları (kW)	0.37
Güç konveyör motorları (kW)	0.25
Maks. kaynatabileceği profil yükseklik / genişlik (mm)	H: 180 / W: 130
Min. kaynatabileceği profil yükseklik / genişlik (mm)	H: 30 / W: 30
Maks. / Min. kaynak çerçeve ölçüleri (mm)	3.100 x 2.700 / 400 x 400
CNC TEMİZLEME (CNC 608/ CNC 610)	
Eksen hızları (Y/Z) (m/dk.)	Y: 30 / Z: 30
Güç (servo motorlar) (kW)	0,85
Güç (testere motoru) (kW)	0,75
Güç (freze motorları) (kW)	0,22
Testere motoru devir (dev./dk.)	6.000
Freze motorları devir (dev./dk.)	18.000
Takım sayısı	11
Maksimum İşleyebileceği profil yükseklik ve genişlik (mm)	H: 180 / W: 130
Minimum işleyebileceği profil yükseklik ve genişlik (mm)	H: 30 / W: 30
Maks./ Min. İşleyebileceği çerçeve ölçüleri (mm)	2.200 x 2.200 / 400 x 400
TAŞIMA ROBOTU (SA 260)	
Maksimum güç (kW)	0.85
Maksimum taşıyabileceği profil yükseklik / genişlik (mm)	H: 130 / W: 130
Minimum taşıyabileceği profil yükseklik / genişlik (mm)	H: 30 / W: 30
Maks. / Min. taşıyabileceği çerçeve ölçüsü	2.200 x 2.200 / 400 x 400
GENEL	
Net / gross weight (kg)	3.776 / 3.931
Paketleme ölçüleri (cm)	1 ad x 3,35 x 0,34 x 2,3 1 ad x 3,3 x 0,34 x 2,32 1 ad x 5,7 x 0,82 x 1,12 1 ad x 1,9 x 2,04 x 1,05
Gerekli hava basıncı (bar)	6-8
Voltaj-Frekans-Akım	400V AC 3P N PE 50/60 Hz.
Toplam güç (CNC 608 ile /CNC 610 ile) (kW)	12 / 14



CUTTING
KESİM



KD 402 S

DOUBLE HEAD MITRE SAW MACHINE
ÇİFT KAFA KESME MAKİNESİ

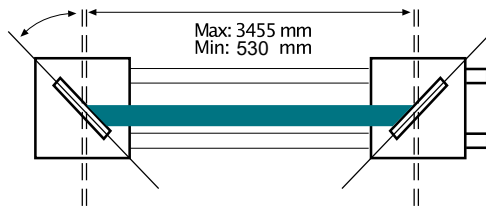
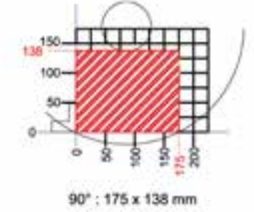
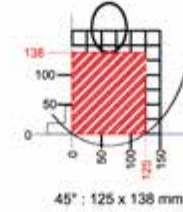
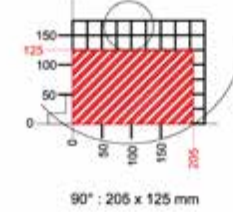
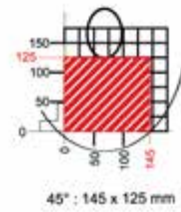
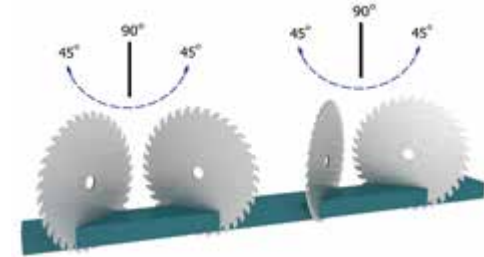

			Bar	Air Cons.		WxLxH cm
4.500W / 9A 400V AC 3P PE 50-60 Hz.	D: Ø400 mm d: Ø30-32 mm	2.900 RPM	6-8 Bar	46 L/min.	195x556x144	495 593

GENERAL FEATURES

- Two-hand safety operation
- Semi-automatic miter saw with two circular saws designed for flat or angled cutting of PVC, aluminium and wooden materials
- Location points at 0°, 15°, 22.5°, 30° and 45 both left and right
- Pivoting range +45° - 45° inwards and outwards infinitely adjustable
- The left cutting unit is fixed, and the right cutting unit is moved manually to its position
- Hydro-pneumatic saw feed
- Manual positioning of sawing heads
- On/off switch for horizontal clamp
- Pressure control valves on the clamps for the adjustment of the profile fixing
- Pneumatic head fixing feature
- The distance between the cutting heads can be adjusted accurately by a digital display
- Max. cut length: 3.455 mm, min cut length: 530 mm
- The power of sawing motors: 2 x 2.2 kW

STANDARD ACCESSORIES

- Equipped with 2 x Ø400 mm of saw blades
- Profile support mechanism
- 3 x pneumatic horizontal clamps
- 2 x pneumatic vertical clamps
- Digital display indicating the cutting length
- Pneumatic spray mist lubrication system
- Air gun

OPTIONAL ACCESSORIES

- VCE 1570 chip vacuum extractor & accessories
- Two-step of head speed control system (patented)
- Spare saw blade Ø400 mm

GENEL ÖZELLİKLER

- Çift el kumanda uygulaması
- PVC, alüminyum ve ahşap malzemeleri kesmek amacı ile 2 testereli kesme ünitesi
- 0°-15°-22.5°-30°-45°'lik açılarda içeri ve dışarı susta ile kesim
- 45° sol - 45° sağ ara derecelerde hassas kesim
- Sol kesme ünitesi sabit olup sağ kesme ünitesi pozisyona manuel olarak kaydırılarak kesme yapılır
- Hidro-pnömatik kontrollü testere hareketi
- Kesme kafalarının manuel olarak pozisyonlanması
- Yatay mengener için açma/kapama butonu
- Mengene profil sıkma ayarları için basınç kontrol valfleri
- Pnömatik kafa sabitleme özelliği
- Dijital ekran ile profil kesim boyunun optimum olarak ayarlanması
- Maksimum kesme boyu 3.455 mm ve minimum kesme boyu 530 mm
- Testere motoru gücü: 2 x 2.2 kW

STANDART AKSESUARLAR

- 2 x Ø400mm testere
- Profil destek ünitesi
- 3 x pnömatik yatay mengene
- 2 x pnömatik dikey mengene
- Kesim boyunu gösteren dijital ekran
- Püskürtmeli testere soğutma sistemi
- Hava tabancası

OPSİYONEL AKSESUARLAR

- VCE 1570 talaş emme sistemi & aksesuarları
- Kesme kafalarında iki kademeli hız kontrol sistemi (patentli)
- Yedek testere Ø400mm







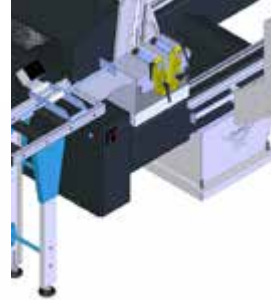

DC 421 PSD

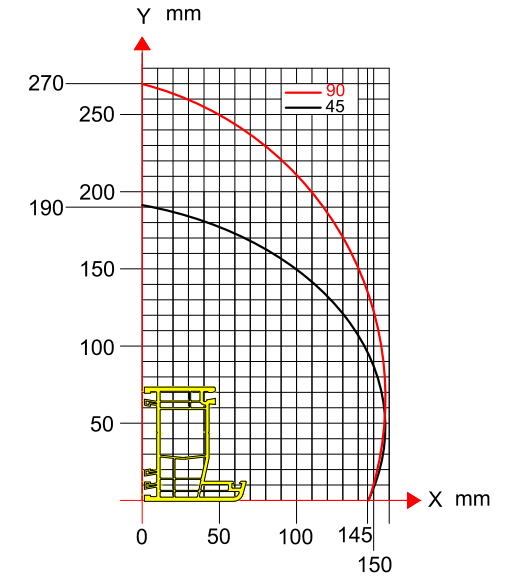
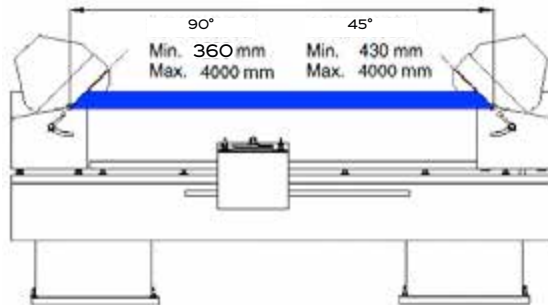
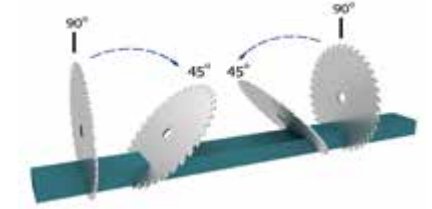
FULL AUTOMATIC DOUBLE HEAD MITRE SAW MACHINE
TAM OTOMATİK ÇİFT KAFA KESME MAKİNESİ

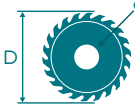

Short cut system
Kısa profil kesme sistemi



						
			Bar	Air Cons.		
5 kW / 4A 400V AC 3P PE 50-60 Hz,	D: Ø420 mm d: Ø30-32 mm	2.900 RPM	6-8	160 L/min.	145x451x167	830 949

GENERAL FEATURES

- Two-hand safety operation
- Tilting automatically to 90° and 45° inwards for both angles. Manual adjustment of other intermediate angles from 90° to 45° inwards
- Automatic slicing feature at 90° and 45° inward
- Hydro-pneumatic saw blade feed
- Cutting accuracy +/- 0.2 mm
- Solid steel construction of the body
- Automatically closing safety guards
- 9" touch screen operator panel
- Cutting list transfer with 'csv' format via USB
- Obtains profile cutting dimensions and angles from the cut list while working in automatic mode
- The power of sawing motors: 2 x 2.2 kW

STANDARD ACCESSORIES

- Roller conveyor & 2x pneumatic profile supports
- Spray saw blade lubrication system
- 2x Ø420 mm of saw blade
- 4x horizontal clamps
- 2x pneumatic vertical clamps
- Air gun

OPTIONAL ACCESSORIES

- DKN 70 short cut system (digital)
- DKN 71 short cut system (with ruler)
- DKN 80 arrow cut system for mullion profiles
- VCE 1570 Chip vacuum extractor
- Spare saw blade, Ø420
- Mould heights for special profiles
- Machine with the length of 5m and 6m
- RS 1000 profile support foot
- Barcode printer

GENEL ÖZELLİKLER

- Çift el çalıştırma güvenliği
- 90° ve 45° içe iki açıya otomatik olarak pozisyona gelir. Diğer ara derecelerde kesme üniteleri manuel olarak ayarlanarak serbest kesim yapılır
- 90° ve 45° iç açıda sabit kafada otomatik dilimleme özelliği
- Hidro-pnömatik kontrollü testere hareketi
- Kesme hassasiyeti +/- 0.2 mm
- Çelik konstrüksiyon gövde
- Otomatik olarak kapanan muhafaza kapakları
- 9" dokunmatik renkli operatör paneli
- USB bellek ile 'csv' formatta kesim listesi transferi
- Otomatik konumda çalışırken profil ölçüleri ve açılarını kesim listesinden alır
- Testere motorlarının gücü 2 x 2.2 kW

STANDART AKSESUARLAR

- Konveyör & 2x pnömatik profil destek ünitesi
- Püskürtmeli testere soğutma sistemi
- 2x Ø420 mm testere
- 4x pnömatik yatay mengene
- 2x pnömatik dikey mengene
- Hava tabancası

OPSİYONEL AKSESUARLAR

- DKN 70 kısa profil kesme sistemi (dijital)
- DKN 71 kısa profil kesme sistemi (metreli)
- DKN 80 orta kayıt profilleri için ok kesme sistemi
- VCE 1570 Talaş emme sistemi & aksesuarları
- Yedek Ø 420 mm testere
- Özel profiller için kesme kalıpları
- 5m ve 6m boyunda özel makine
- Yedek Ø420 mm testere
- RS 1000 profil destek ayağı
- Barkod yazıcı

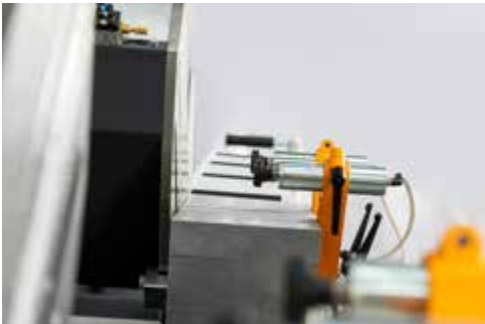





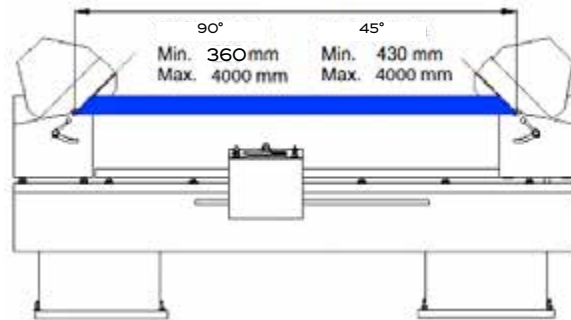
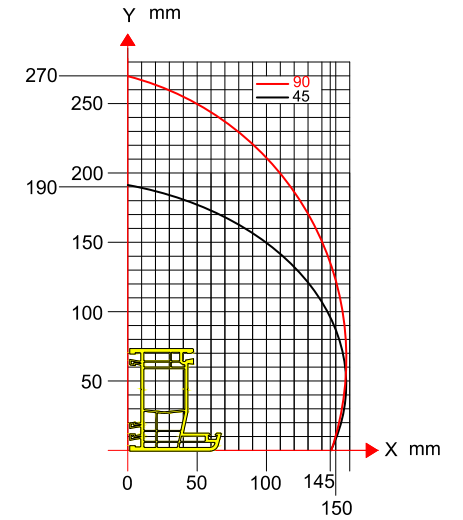
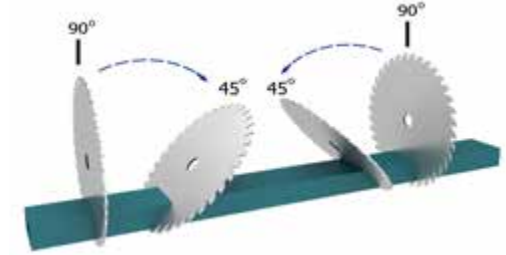

DC 421 PBS

FULL AUTOMATIC DOUBLE HEAD MITRE SAW MACHINE
TAM OTOMATİK ÇİFT KAFA KESME MAKİNESİ

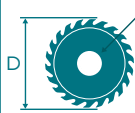

Barcode printer
Barkod yazıcı



						
			Bar	Air Cons.		
5 kW / 4A 400V AC 3P PE 50- 60 Hz.	D: Ø420 mm d: Ø30-32 mm	2.900 RPM	6-8	165 L/min.	145x451x167	888 965

GENERAL FEATURES

- Two-hand safety operation
- Tilting automatically to 90° and 45° inwards for both angles. Manual adjustment of other intermediate angles from 90° to 45° inwards
- Automatic slicing feature at 90° and 45° inward
- Hydro-pneumatic saw blade feed
- Cutting accuracy +/- 0.2 mm
- Solid steel construction of the body
- Automatically closing safety guards
- Windows based industrial PC and 15" LCD touch screen colour monitor
- Facility to transfer the cutting list in 'mdb' and 'csv' format via USB and network
- Obtains profile cutting dimensions and angles from the cut list while working in automatic mode
- Technical support via remote connection capability
- The power of sawing motors: 2 x 2.2kW

STANDARD ACCESSORIES

- Roller conveyor & 2x pneumatic profile supports
- Spray saw blade lubrication system
- 4x pneumatic horizontal clamps
- 2x pneumatic vertical clamps
- 2x Ø420 mm of saw blade
- Air gun
- Barcode printer

OPTIONAL ACCESSORIES

- DKN 70 short cut system (digital)
- DKN 71 short cut system (with ruler)
- VCE 1570 chip vacuum extractor
- Spare saw blade Ø420
- Mould heights for special profiles
- DKN 80 arrow cut system for mullion profiles
- RS 1000 profile support foot
- Machine with the length of 5m & 6m

GENEL ÖZELLİKLER

- Çift el çalıştırma güvenliği
- 90° ve 45° içe her iki açıya otomatik olarak pozisyona gelir. Diğer ara derecelerde kesme üniteleri manuel olarak ayarlanarak serbest kesim yapılır
- 90° ve 45° iç açıda sabit kafada otomatik dilimleme özelliği
- Hidro-pnömatik kontrollü testere hareketi
- Kesme hassasiyeti +/- 0.2 mm
- Çelik konstrüksiyon üretilmiş gövde
- Otomatik olarak kapanan muhafaza kapakları
- Windows tabanlı endüstriyel PC ve 15" LCD dokunmatik renkli panel ekran
- USB bellek ve network üzerinden "mdb" ve "csv" formatta kesim listesi transferleri
- Otomatik konumda çalışırken profil kesim ölçüleri ve açılarını kesim listesinden alır
- Uzak bağlantı ile teknik destek
- Testere motorlarının gücü: 2 x 2.2kW

STANDART AKSESUARLAR

- Konveyör & 2x pnömatik profil destek ünitesi
- Püskürtmeli testere soğutma sistemi
- 4x pnömatik yatay mengene
- 2x pnömatik dikey mengene
- 2x Ø420 mm testere
- Hava tabancası
- Barkod yazıcı

OPSİYONEL AKSESUARLAR

- DKN 70 kısa profil kesme sistemi (dijital)
- DKN 71 kısa profil kesme sistemi (metreli)
- VCE 1570 Talaş emme sistemi
- Yedek Ø420 mm testere
- Özel profiller için kesme kalıpları
- DKN 80 orta kayıt profilleri için ok kesme sistemi
- RS 1000 profil destek ayağı
- 5m ve 6m boyunda özel makine



ACK 420 S

UP-CUTTING SAW MACHINE
ALTTAN ÇIKMA KESME MAKİNESİ



*Horizontal clamps on the picture are optional
*Fotoğrafta görülen yatay mengenerler opsiyoneldir

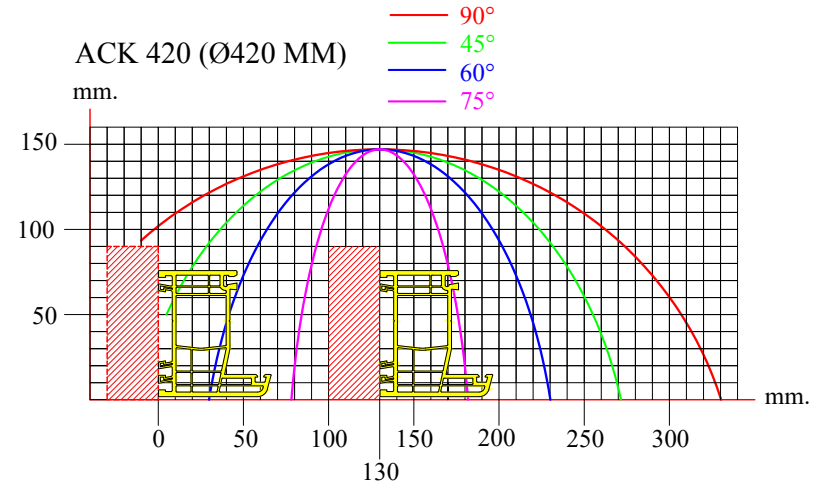
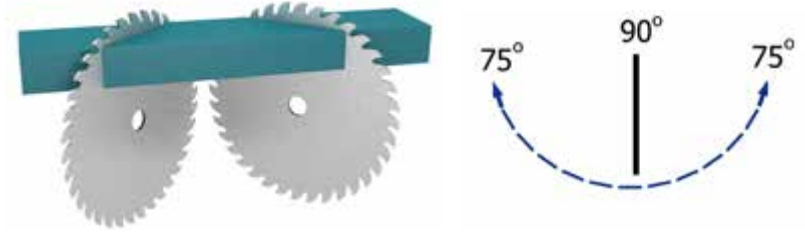

VCE 1570
Swarf vacuum extractor
Talaş emme sistemi

			Bar	Air Cons.	
2.2 kW 400V AC 3P PE 50-60 Hz,	D: Ø420 mm d: Ø30/32 mm	2.900 RPM	6-8	130 L/min.	113x426x131
					210 250

GENERAL FEATURES

- Two-hand safety operation
- Location points at 75°, 60°, 45°, 30°, 22.5°, 15°, 0° both left and right
- Pivoting range from -75° left to +75° right infinitely adjustable
- Hydro-pneumatic saw feed
- Adjustable back fence for most effective use of the saw blade
- Adjustable saw blade feeding speed
- Manually opening safety guard
- Interior LED lighting

STANDARD ACCESSORIES

- Equipped with saw blade Ø420 mm
- Manuel MKN 300 length stop (3m)
- 2x pneumatic vertical clamps
- 2x in-feed & out-feed tunnels for operator safety
- Spray saw blade lubrication system
- Air gun
- Swarf manifold top

OPTIONAL ACCESSORIES

- Laser marker indicating the cutting line
- Spare saw blade, Ø420 mm
- Additional 2x pneumatic horizontal clamp
- VCE 1570 Chip vacuum extractor
- DKN 302 length stop
- DKN 602 length stop
- SKN 300 length stop
- SKN 600 length stop
- Swarf manifold bottom

GENEL ÖZELLİKLER

- Çift el kumanda uygulaması
- 75°, 60°, 45°, 30°, 22.5°, 15°, 0° açılarda sağ ve sol yönde susta ile kesim
- -75° sol ve +75° sağ tüm ara derecelerde hassas kesim
- Hidro-pnömatik kontrollü testere hareketi
- Daha yüksek kesim kapasitesi için hareketli gönye
- Ayarlanabilir testere çıkış hızı
- Manuel olarak açılan koruma kapağı
- Kabin içi LED aydınlatma

STANDART AKSESUARLAR

- Ø420 mm testere
- Manuel MKN 300 konveyör (3m)
- 2x dikey mengene
- 2x makine giriş ve çıkışına operatör güvenlik tüneli
- Püskürtmeli testere soğutma sistemi
- Havba tabancası
- Talaş manifoldu üst

OPSİYONEL AKSESUARLAR

- Kesme hattını gösteren lazer işaretleme seti
- Yedek Ø420 mm testere
- İlave 2x pnömatik yatay mengene
- VCE 1570 Vakum talaş emme sistemi
- DKN 302 konveyör
- DKN 602 konveyör
- SKN 300 konveyör
- SKN 600 konveyör
- Talaş manifoldu alt

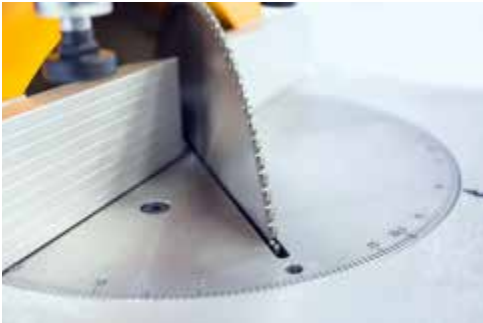





MK 420 - MK 420 PS MK 450

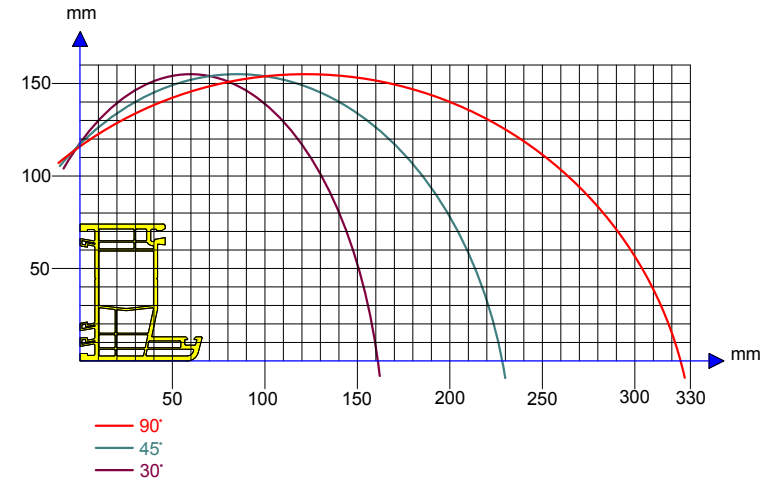
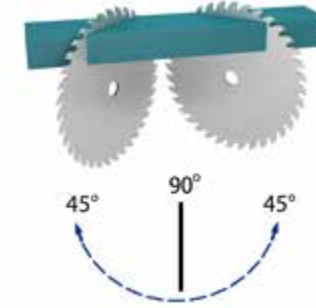

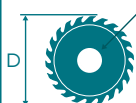
MANUAL UP-CUTTING SAW MACHINE
MANUEL ALTTAN ÇIKMA KESME MAKİNESİ



							
					Bar	Air Cons.	
MK 420	2.2 kW 230V AC 1P PE 50-60 Hz,	D: Ø420 mm d: Ø30/32 mm	2.900 RPM	72.5x86.5x135	-	-	115
							142
MK 420 PS	2.2 kW 400V AC 3P PE 50-60 Hz,	D: Ø420 mm d: Ø30/32 mm	2.900 RPM	72.5x86.5x135	6-8	7 L/min.	131
							159
MK 450	2.2 kW 4A 400V AC 3P PE 50-60 Hz,	D: Ø450 mm d: Ø30/32 mm	2.900 RPM	72.5x86.5x135	-	-	120
							143

GENERAL FEATURES

- Manual upward saw stroke
- The back fence is adjustable to allow the most effective use of the saw blade capacity for wide and flat profiles
- Location points at 60°, 45°, 30°, 22.5°, 15°, 0° for both left and right
- Wide angle cutting range up to 60° to the right and 60° to the left
- Adjustable machine working direction by means of rotatable (360°) platform via. foot pedal
- Easy saw blade change
- It has the ability of lateral and longitudinal cutting operations

STANDARD ACCESSORIES

- Equipped with saw blade Ø420 mm
- Equipped with saw blade Ø 450 mm (MK 450)
- Miter stop
- Profile length stop
- Pneumatically working spray saw blade lubrication system (MK 420 PS)
- Electrically working spray saw blade lubrication system (MK 420- MK 450)
- 2 x mechanic top clamps (MK 420)
- 2 x pneumatic top clamps (MK 420 PS)
- Safety guard for lateral cutting operations (MK 420 PS)

OPTIONAL ACCESSORIES

- Safety guard for longitudinal cutting operations (MK 420 PS)
- 2 x vertical clamps
- MKN length stop (3m)
- Connection kit for MKN and DKN length stops
- Spare saw blade, Ø420 mm
- Spare saw blade, Ø450 mm (MK 450)

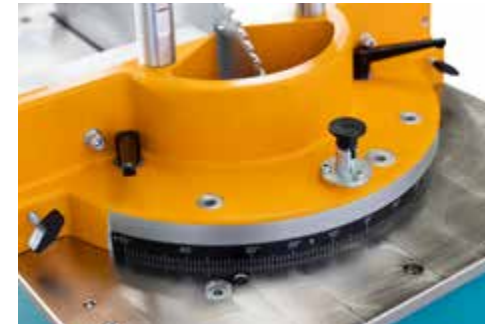

GENEL ÖZELLİKLER

- Manuel olarak yukarı hareket eden testere mekanizması
- Ayarlanabilir arka dayama ile geniş ve uzun profillerde testere kapasitesini optimum olarak kullanılır
- 60°, 45°, 30°, 22.5°, 15°, 0° açılarda sağ ve sol yönde susta ile kesim
- 60° sağ ve 60° sol tarafa dönebilen geniş açılı kesme kapasitesi
- Ayak pedali ile 360° dönen özel kesim ünitesi ile makine çalışma yönü ayarlanabilir
- Kolay testere değiştirme
- Enine ve boyuna kesme (biçme) yapabilme imkanı

STANDART AKSESUARLAR

- Ø420 mm testere
- Ø450 mm testere takılı olarak (MK 450)
- Gönye dayama
- Profil dayama
- Pnömatik olarak çalışan püskürtmeli testere soğutma sistemi (MK 420 PS)
- Elektrik ile çalışan testere soğutma sistemi (MK 420 - MK 450)
- 2x mekanik üst mengene (MK 420)
- 2x pnömatik üst mengene (MK 420 PS)
- Enine kesme için güvenlik kapağı (MK 420 PS)

OPSİYONEL AKSESUARLAR

- Boyuna kesme (biçme) için güvenlik kapağı (MK 420 PS)
- 2x dikey mengene
- MKN 300 konveyör
- MKN ve DKN konveyörler için bağlantı kiti
- Ø420 mm yedek testere
- Ø450 mm yedek testere (MK 450)

RYK 420 W



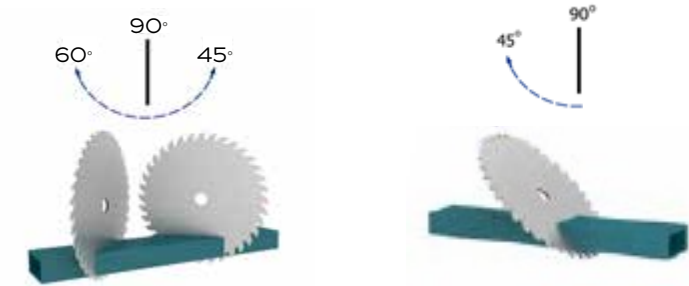

RADIAL SAW MACHINE
RADYAL KESİM MAKİNESİ

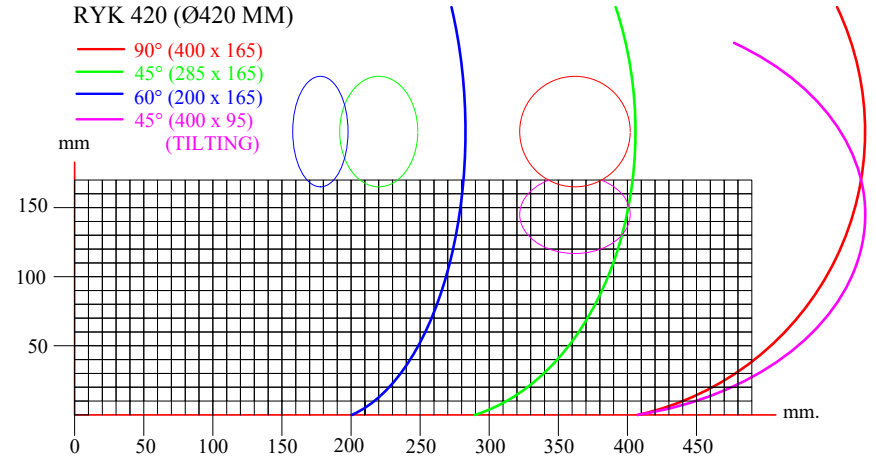

RYK 420 (Ø420 MM)

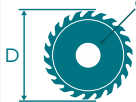
- 90° (400 x 165)
- 45° (285 x 165)
- 60° (200 x 165)
- 45° (400 x 95)
(TILTING)



						
				WxLxH cm	Bar	
2.2 kW 4.7A 400/415V AC 3P 50-60 Hz,	D: Ø420 mm d: Ø30/32 mm	2.900 RPM	184x76x159	6-8	24 L/ min.	202 255

GENERAL FEATURES

- Performing of different cutting operations are possible by means of the pivoting and tilting features
- Powerful cutting operations by means of the 2.2 kW 3.000 RPM motor
- Smooth movement, high precision and great sensitivity provided with gas spring, linear bearings and ergonomic handle
- Cast iron construction of the body that is strong and lasting
- Robust mechanical construction enables the ease of adjustment for the requested cutting angles
- Location points at 15° - 22,5° - 30° - 45° - 60° - 90° both left and right
- Pivoting range from 45° right to 60° left infinitely adjustable
- Tilting range from 90° to 45° left

STANDARD ACCESSORIES

- Equipped with Ø420 mm saw blade for wood and PVC cutting operations
- Digital display for ease adjustment of pivoting angle
- Laser marking indicating the cutting line
- Brake unit working with motor stop button
- 2x pneumatic vertical clamp
- Air gun

OPTIONAL ACCESSORIES

- Hydraulic control unit for saw head feed rate
- Special miter for longitudinal cutting operations
- Spare saw blade for PVC and wood cutting, Ø420 mm
- Connection kit for DKN and MKN length stops
- DKN 602 length stop



GENEL ÖZELLİKLER

- Testerenin kaidesinin yatar ve döner özelliği ile farklı kesim operasyonları yapmak mümkündür
- 2.2 kW, 3.000 RPM kesme motoru ile güçlü kesme operasyonları
- Kesme işlemlerini kolaylaştıran yüksek hassasiyetli lineer yataklama, gaz amortisörler ve ergonomik kol tasarımı
- Dökme demir malzemeden imal edilmiş makine gövdesi ve çelik sacdan üretilmiş makine sehpası
- İstenilen açılara kolay ayarlanabilir mekanik altyapı
- 15° - 22,5° - 30° - 45° - 60° - 90°' lik açılarda sağ ve sol yönde susta ile kesim
- 60° sağ - 45°sol ara derecelerde hassas kesim
- 90°- 45° aralığında sola yatar kesim

STANDART AKSESUARLAR

- Ahşap ve PVC malzeme kesmeye uygun Ø420 mm testere takılı olarak
- Tabla dönme açısını gösteren dijital açı okuyucu
- Kesme hattını gösteren lazer işaretleme
- Motor stop butonu ile çalışan frenleme tertibatı
- 2x pnömatik dikey mengene
- Hava tabancası





OPSİYONEL AKSESUARLAR

- Hidrolik geri frenleme sistemi
- Biçme operasyonları için özel gönye
- Yedek Ø420 mm ahşap kesim testeresi
- DKN ve MKN konveyörler için bağlantı kiti
- DKN 602 konveyör

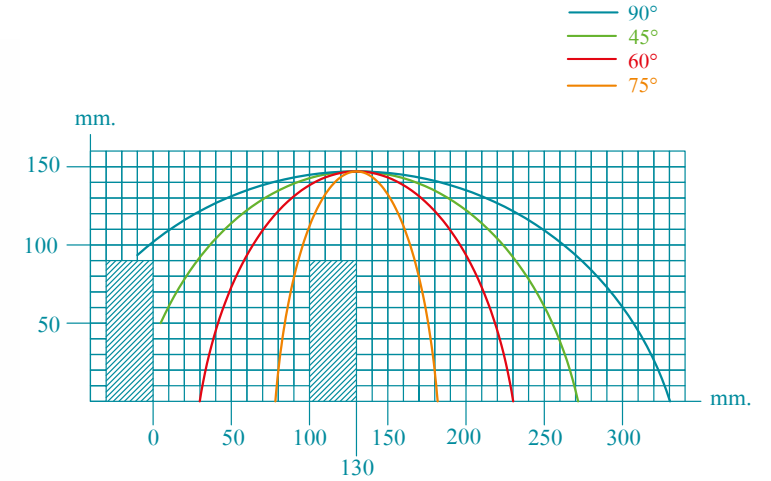
SCM 420 L4 - SCM 420 L7

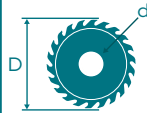
SERVO CONTROLLED SERIAL CUTTING MACHINE
SERVO KONTROLLÜ SERİ KESİM MAKİNESİ



							
				Bar	Air Cons.		
SCM 420 L4	2.2 kW 400V AC 3P PE 50-60 Hz.	D: Ø420 mm d: Ø30/32 mm	2.900 RPM	6-8	130 L/min.	113x525x136	220 450
SCM 420 L7	2.2 kW 400V AC 3P PE 50-60 Hz.	D: Ø420 mm d: Ø30/32 mm	2.900 RPM	6-8	130 L/min.	113x825x136	325 529

GENERAL FEATURES

- 3.6 m (SCM 420 L4) and 6.6 m (SCM 420 L7) pushing strokes with 300 of conveyor width
- Automatic and manual operation features
- Automatic serial cutting at 90°
- Manual cutting with location points at 75°, 60°, 45°, 30°, 22.5°, 15°, 90°, both left and right
- Two-hand run safety operation
- Hydro-pneumatic saw feed
- Adjustable saw blade feeding speed
- Turkish, English, Spanish and Russian
- Metric and imperial
- Store up to 50 different lengths
- Easy cutting lists transfer in CSV format with SD card
- 7" HMI colored touch screen monitor
- Preparing cutting lists manually
- Ability to change the cutting list on screen
- Problem solving with remote connection feature
- Units can be converted from Left to Right Hand operation
- Rack and pinion drive mechanism and rigid steel of construction body provide a repeatable cutting accuracy of +/- 0.2 mm providing superior pushing force for heaviest jobs
- Pieces are cut in the order according to the measurement data that is sent from the digital measuring rod (1.5 m, 3.0 m) (optional)

STANDARD ACCESSORIES

- Equipped with saw blade Ø420 mm
- 2x vertical clamps and 1x horizontal roller clamp
- Spray saw blade lubrication system
- Air gun

OPTIONAL ACCESSORIES

- Laser marker set indicating the cutting line
- Barcode printer
- Extendible digital measuring rod, 3.0 m
- Spare saw blade Ø420 mm
- VCE 1570 Chip vacuum extractor
- MKN 150 outfeed conveyor



GENEL ÖZELLİKLER

- 3.6 m (SCM 420 L4) ve 6.6 m (SCM 420 L7) itme stroğu ve 300 mm konveyör genişliği ile hassas kesim
- Manuel ve otomatik çalışma özelliği
- 90 derecede otomatik seri kesim
- 75°, 60°, 45°, 30°, 22.5°, 15°, 90° açılarda sağ ve sol yönde susta ile manuel kesim
- Çift el kumanda uygulaması
- Hidro-pnömatik kontrollü testere
- Ayarlanabilir testere çıkış hızı
- Türkçe, İngilizce, Rusça ve İspanyolca dillerde kullanım menüsü
- Metrik ve İnç ölçü sistemi
- 50 adet farklı kesim ölçüsü oluşturabilme
- SD kart ile CSV formatında kesim listeleri transferi
- 7" HMI dokunmatik renkli panel ekran
- Manuel reçete oluşturma
- Ekran üzerinden kesim listesinde değişiklik yapabilme özelliği
- Uzaktan bağlanma ve problem çözme
- Konveyör mekanizması sol beslemeden sağ beslemeye dönüştürülebilir
- Kremayer & pinyon dişli sürme mekanizması ve çelik konstrüksiyon yapısı sayesinde ağır malzemeleri yüksek hassasiyet ile +/- 0.008" (0.2mm) pozisyonlama sağlar
- Dijital ölçü alma aparatı ile kablosuz ölçü alma özelliği (1.5 m, 3.0 m) (opsiyonel)

STANDART AKSESUARLAR

- Ø420 mm testere
- 2x dikey ve 1x yatay döner mengene
- Püskürtmeli testere soğutma sistemi
- Hava tabancası

OPSİYONEL AKSESUARLAR

- Kesme hattını gösteren lazer işaretleme seti
- Barkod printer
- Dijital ölçü alma aparatı (3.0m)
- Yedek Ø420 mm testere
- VCE 1570 Vakum talaş emme sistemi
- MKN 150 dış besleme konveyörü

CK 412

PVC GLAZING BEAD SAW
PVC ÇİTA KESME MAKİNESİ

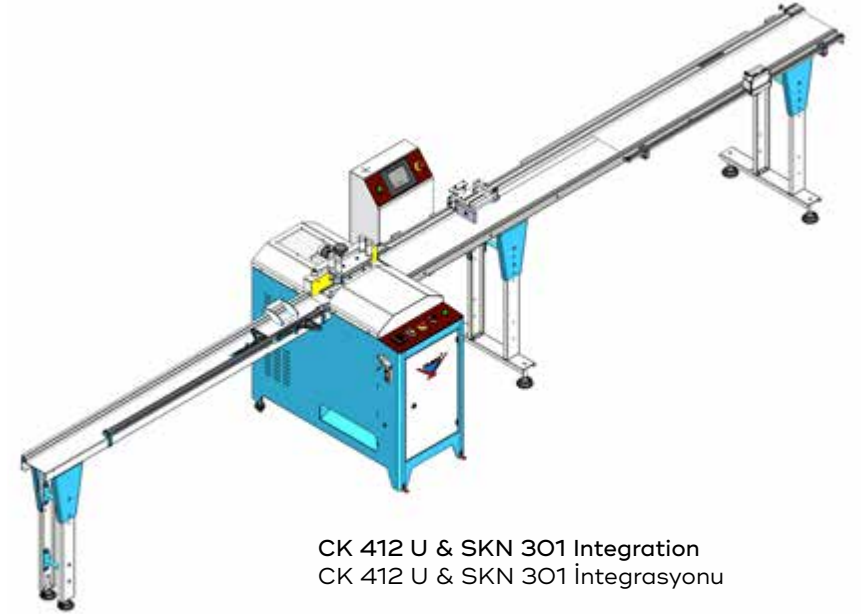

CK 412 U & SKN 301 Integration
CK 412 U & SKN 301 İntegrasyonu

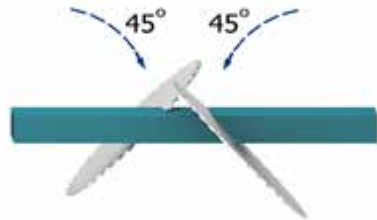

				Bar	Air Cons.		
2.440W 400V AC 3P PE 50-60 Hz,	Wmax:40 mm Wmin:10 mm H2max:30 mm H1max:36 mm	D1:Ø103 mm D2:Ø200 mm d:Ø30-32 mm	3.000 RPM	6-8	130 L/min.	103.5x249.5x108	121 149

GENERAL FEATURES

- Adjustable saw blade feeding speed
- Pneumatic saw feed by pushing button
- Equipped with 2x pneumatic vertical clamps
- Automatic return to start point of the process
- Twin blade design
- Ability to cut 8 different glazing bead profiles without a mould by using mechanical memory

STANDARD ACCESSORIES

- 1x Ø200 and 1x Ø103 mm saw blades
- KN 152 roller conveyor with manual measuring unit
- Air gun

OPTIONAL ACCESSORIES

- Electrical foot pedal and regulator & monometer for the vertical clamps
- SKN 301 length stop together with 1.5 m of digital measuring unit
- SKN 301 length stop together with 3.0 m of digital measuring unit
- MKN 300 length stop
- SKN 300 length stop
- SKN 600 length stop
- Digital measuring rod 3.0 m (for SKN 300 & SKN 600 application)
- Spare saw blade, Ø200 mm
- Spare saw blade, Ø103 mm
- Moulds for special glazing beads
- KN 152 roller conveyor for outfeeding

GENEL ÖZELLİKLER

- Ayarlanabilir testere ilerleme hızı
- Tek bir butona basarak pnömatik testere hareketi başlar
- 2x pnömatik dikey mengenerler
- İşlemin otomatik olarak başlangıç noktasına dönme özelliği
- Çift testere sistemi
- Mekanik hafıza kullanarak 8 ayrı çıta profilini kalıpsız kesme imkanı

STANDART AKSESUARLAR

- 1x Ø200 ve 1x Ø103 mm testere
- KN 152 konveyör ve mekanik ölçü alma aparatı
- Hava tabancası

OPSİYONEL AKSESUARLAR

- Elektrik kumandalı ayak pedali ve dikey mengenerler için regülatör & manometre
- SKN 301 konveyör & 1.5 m ölçü alma aparatlı kit
- SKN 301 konveyör & 3.0 m ölçü alma aparatlı kit
- MKN 300 konveyör
- SKN 300 konveyör
- SKN 600 konveyör
- Dijital ölçü alma aparatı 3.0 m (SKN 300 & SKN 600 uygulaması için)
- Yedek Ø200 mm testere
- Yedek Ø103 mm testere
- Özel çıta profiller için kalıplar
- Çıkış tarafına KN 152 konveyör



SDT 280

SEMI-AUTOMATIC REINFORCEMENT STEEL AND
PROFILE MULTI CUTTING MACHINE

YARI OTOMATİK ÇOKLU DESTEK SACI VE
PROFİL KESME MAKİNESİ



3,5 kW 400V AC 3P PE 50-60 Hz,	Bandsaw: 3.660x27x0.9	0-60 RPM	WxLxH cm 200x41x160	900 1.000

CUTTING CAPACITY	
90° Round (mm)	280
90° Square (mm)	280
90° Rectangle (mm)	280x320
45° Round (mm)	150
45° Square (mm)	150
45° Rectangle (mm)	150x280
BAND SAW	
Band saw feed-rate (m/min.)	0-60
Band saw dimensions (mm)	3.660x27x0.9
HYDRAULIC UNIT	
Boron oil depot (Lt)	30
Hydraulic storage (Lt)	15
MOTORS	
Main motor (kW)	2.2
Hydraulic motor (kW)	0.75
Boron oil motor (kW)	0.09
Conveyor motor (kW)	0.44
MACHINE DIMENSIONS	
Length (mm)	1.900
Width (mm)	1.100
Height (mm)	1.500
Weight (kg)	800

KESME KAPASİTESİ	
90° Yuvarlak (mm)	280
90° Kare (mm)	280
90° Dikdörtgen (mm)	280x320
45° Yuvarlak (mm)	150
45° Kare (mm)	150
45° Dikdörtgen (mm)	150x280
ŞERİT TESTERE	
Şerit testere hızı (m/dk.)	0-60
Şerit testere ölçüleri (mm)	3.660x27x0.9
HİDROLİK	
Bor yapı deposu (L)	30
Hidrolik depo (Lt)	15
MOTORLAR	
Ana motor (kW)	2.2
Hidrolik motor (kW)	0.75
Bor yağı motor (kW)	0.09
Konveyör motor (kW)	0.44
MAKİNE BOYUTLARI	
Uzunluk (mm)	1.900
En (mm)	1.100
Yükseklik (mm)	1.500
Ağırlık (kg)	800

GENERAL FEATURES

- Hydraulic top clamping unit holding the bundled materials firmly
- Hydraulically operated band saw tension mechanism
- 2x adjustable micro spray cooling units
- Band saw frame that can move up and down hydraulically
- Speed control unit that adjust the band saw speed according to the material
- Speed control valve that adjusts the band saw downward speed according to the material
- Band saw frame made of hard steel and chrome coated and grinded two pillars providing a high degree of accuracy
- Chip brush that cleans the band saw during the cutting operation
- The machine automatically switch off at the end of the cut and band saw frame is lifted hydraulically
- Compact and rugged machine construction

STANDARD ACCESSORIES

- Chip conveyor unit that removes the cutting chips from the environment
- 3 meters of infeed roller table placed on the entrance of the machine
- 2° inclined bimetal band saw fitted on the machine bow



GENEL ÖZELLİKLER

- Bağ halinde kesilecek malzemeleri tutan hidrolik üst mengene grubu
- Hidrolik olarak çalışan şerit testere germe mekanizması
- 2x ayarlanabilir mikro sprey soğutucu
- Hidrolik olarak aşağı ve yukarı hareket edebilen şerit testere çerçevesi
- Malzemeye göre şerit testere devrini ayarlayan hız kontrol ünitesi
- Malzemeye göre şerit testere aşağı ilerleme hızını ayarlayan hız kontrol valfi
- Yüksek kesme hassasiyeti sağlayan sert çelikten üretilmiş şerit testere mekanizması ve taşlanmış krom kaplı taşıyıcı sütunlar
- Şerit testereyi kesim operasyonu sırasında temizleyen talaş fırçası
- Kesim bittikten sonra makine kapanır ve testere çerçevesi otomatik olarak kesim yüksekliğine kalkar
- Kompak ve sağlam makine gövdesi

STANDART AKSESUARLAR

- Kesim talaşını ortamdaki uzaklaştıran talaş konveyörü
- Giriş tarafında 3 metre boyunda kesilecek bağ malzemelerin koyulduğu rulo sehpa
- Çerçeveye takılı olarak 2° eğimli çift aşımli şerit testere



SDT 275

REINFORCEMENT STEEL AND SQUARE PROFILE CUTTING SAW
DESTEK SACI VE KARE PROFİL KESME MAKİNESİ



CUTTING CAPACITY	
90° Round (mm)	80
90° Square (mm)	70
90° Rectangle (mm)	110x60
45° Round (mm)	70
45° Square (mm)	60
45° Rectangle (mm)	70x50

KESME KAPASİTESİ	
90° Yuvarlak (mm)	80
90° Kare (mm)	70
90° Dikdörtgen (mm)	110x60
45° Yuvarlak (mm)	70
45° Kare (mm)	60
45° Dikdörtgen (mm)	70x50

1,3 / 1,8 kW 400V AC 3P PE 50-60 Hz,	Dmax Ø275 x d:Ø32 mm	45-90 RPM	WxLxH cm 90x80x120	225 258

GENERAL FEATURES

- Pivoting range 45° to the right and 45° to the left
- Double-speed motor (45/90 RPM)
- Possibility to select the motor speed according to the material
- Ideal for the cutting of reinforcements steels used for PVC Windows
- Cutting capacity: 70 x 70 mm square profile

STANDARD ACCESSORIES

- Equipped with saw blade Ø275 mm
- Manual material clamping system
- Saw blade lubrication system

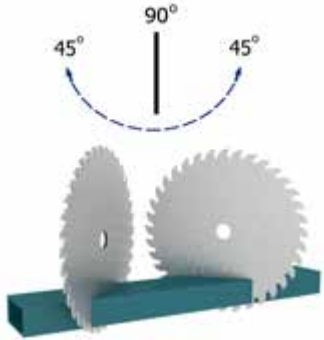

GENEL ÖZELLİKLER

- Sağ ve sol yönde 45° - 45° aralığında kesim
- Çift devirli motor (45-90 dev/dk.)
- Malzemeye göre devir seçebilme imkanı
- PVC pencerelerde kullanılan destek saclarının kesimi için idealdir
- Maks. 70 x 70 mm ölçüsünde kutu profil kesme kapasiteli

STANDART AKSESUARLAR

- Ø275 mm testere takılı olarak
- Manuel yatay mengene sistemi
- Testere soğutma sistemi



KD 400 D - KD 400 PS

MITER SAW MACHINE
DERECELİ KESME MAKİNESİ

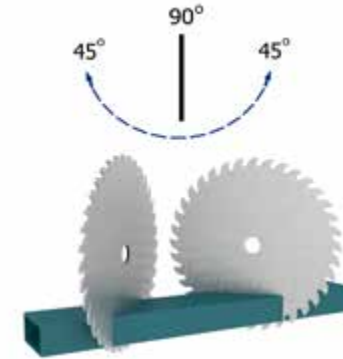

45° : 145 x 125 mm

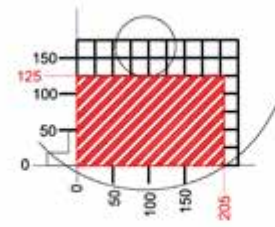

90° : 205 x 125 mm

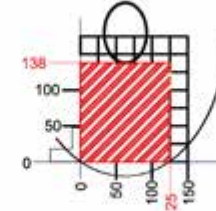



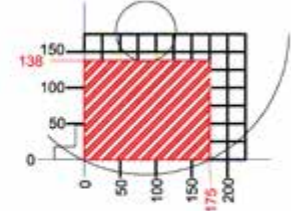

45° : 125 x 138 mm

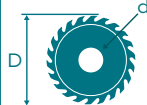

90° : 175 x 138 mm

*The machine above is KD 400 PS.
*Fotoğrafta görülen makine KD 400 PS'dir.

							
				Bar	Air Cons.		
KD 400 D	2.2 kW 400V 3P PE 50-60 Hz.	D: Ø400 mm d: Ø30/32 mm	2.900 RPM	-	-	86x76x160	110 137
KD 400 PS	2.2 kW 400V 3P PE 50-60 Hz.	D:Ø400 mm d: Ø30/32 mm	2.900 RPM	6-8	24 L/min.	86x76x160	115 137

GENERAL FEATURES

- Location points at 45° - 30° - 22.5° - 15° - 0° both left and right
- Pivoting range from 45° left to 45° right infinitely adjustable
- Aluminium construction of the body and machine stand made of steel sheet
- Robust mechanical construction enables the ease of adjustment for the requested cutting angles
- Strong spring system and protective shield

STANDARD ACCESSORIES

- Ø400 mm saw blade
- Machine stand
- 2x manual horizontal clamps (KD 400 D)
- 2x pneumatic horizontal clamps (KD 400 PS)
- Air gun (KD 400 PS)
- Spray saw blade lubrication system (KD 400 PS)

OPTIONAL ACCESSORIES

- 2 x pneumatic vertical clamps (KD 400 PS)
- MKN 300 length stop-right (3m)
- MKN 300 length stop-left (3m)
- DKN 302 length stop (3m)
- DKN 602 length stop (6m)
- Spare saw blade, Ø 400 mm
- Brake unit working with motor stop button (KD 400 PS)

GENEL ÖZELLİKLER

- 45°- 30°- 22.5° - 15°- 0° açılarda sağ ve sol yönde susta ile kesim
- 45° sol - 45° sağ ara derecelerde hassas kesim
- Alüminyumdan imal edilmiş makine gövdesi ve çelik sacdan üretilmiş makine sehпасı
- İstenilen açılara kolay ayarlanabilir mekanik altyapı
- Sağlam yay sistemi ve koruyucu siper (KD 400D)

STANDART AKSESUARLAR

- Ø400 mm testere
- Makine sehпасı
- 2x manuel yatay mengene (KD 400 D)
- 2x pnömatrik yatay mengene (KD 400 PS)
- Hava tabancası (KD 400 PS)
- Testere soğutma sistemi (KD 400 PS)

OPSİYONEL AKSESUARLAR

- 2 x pnömatrik dikey mengene (KD 400 PS)
- MKN 300 konveyör sağ (3m)
- MKN 300 konveyör sol (3m)
- DKN 302 konveyör sağ (3m)
- DKN 602 konveyör (sağ) (6m)
- Yedek Ø 400 mm testere
- Motor durdurma düğmesi ile çalışan fren ünitesi (KD 400 PS)



KD 400 M

MITER SAW MACHINE
DERECELİ KESME MAKİNESİ

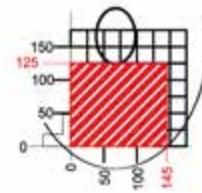
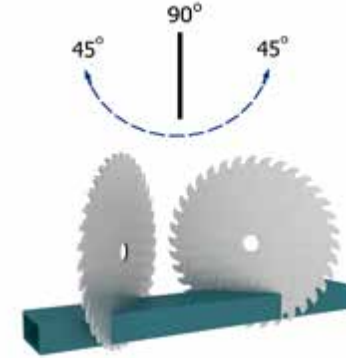

45° : 145 x 125 mm

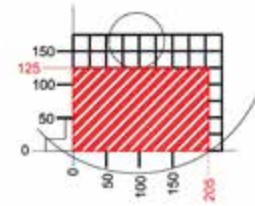

90° : 205 x 125 mm

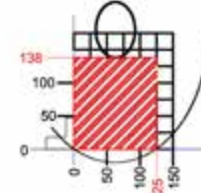

45° : 125 x 138 mm

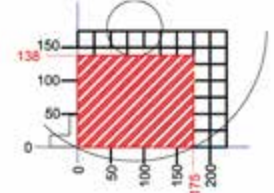

90° : 175 x 138 mm

			Bar	Air Cons.		
2.2 kW 400V AC 3P PE 50-60 Hz.	D: Ø400 mm d: Ø30/32 mm	2.900 RPM	-	-	86x76x83	70 88

GENERAL FEATURES

- Location points at 45° - 30° - 22.5° - 15° - 0° both left and right
- Pivoting range from 45° left to 45° right infinitely adjustable
- Aluminium construction of the body that is strong and lasting
- Robust mechanical construction enables the ease of adjustment for the requested cutting angles
- Strong spring system and protective shield

STANDARD ACCESSORIES

- Equipped with saw blade Ø400 mm
- 2x manual horizontal clamps

OPTIONAL ACCESSORIES

- MKN 300 length stop (3m)
- Machine stand
- Spare saw blade, Ø400 mm

GENEL ÖZELLİKLER

- 45° - 30° - 22.5° - 15° - 0° açılarda sağ ve sol yönde susta ile kesim
- 45° sol - 45° sağ ara derecelerde hassas kesim
- Alüminyumdan imal edilmiş uzun ömürlü ve dayanıklı makine gövdesi
- İstenilen açılara kolay ayarlanabilir mekanik altyapı
- Sağlam yay sistemi ve koruyucu siper

STANDART AKSESUARLAR

- Ø400 mm testere
- 2x manuel yatay mengene

OPSİYONEL AKSESUARLAR

- MKN 300 konveyör (3m)
- Makine sehпасı
- Yedek Ø400 mm testere



KD 350 D - KD 350 PS

MITER SAW MACHINE
DERECELİ KESME MAKİNESİ

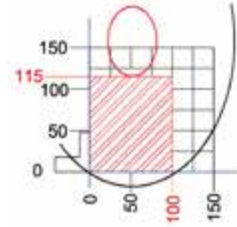
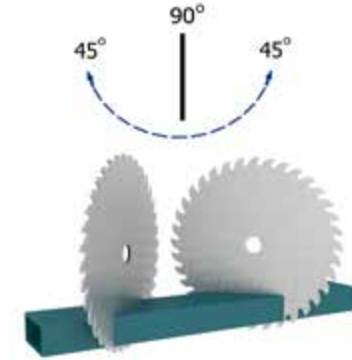

45° : 100 x 115 mm

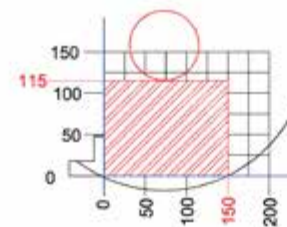

90° : 150 x 115 mm

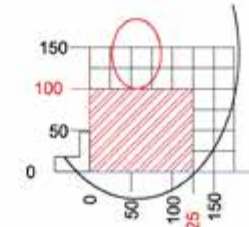

45° : 125 x 100 mm

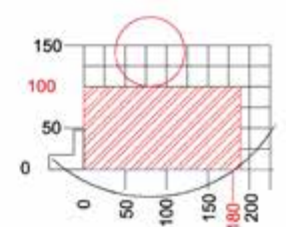

90° : 180 x 100 mm

*The machine above is KD 350 PS.

*Resimde görülen makine KD 350 PS'dir.

				Bar	Air Cons.		
KD 350 D	2.2 kW 400V 50-60 Hz.	D: Ø350 mm d: Ø30-32 mm	2.900 RPM	-	-	72x76x157	109 134
KD 350 PS	2.2 kW 400V 50-60 Hz.	D: Ø350 mm d: Ø30-32 mm	2.900 RPM	6-8	24 L/min.	72x76x157	109 134

GENERAL FEATURES

- Location points at 45° - 30° - 22.5° - 15° - 0° both left and right
- Pivoting range from 45° left to 45° right infinitely adjustable
- Aluminium construction of body and machine stand made of steel sheet
- Robust mechanical construction enables the ease of adjustment for the requested cutting angles
- Strong spring system and protective shield

STANDARD ACCESSORIES

- Machine stand
- Air gun (KD 350 PS)
- Saw blade cooling system (KD 350 PS)
- 2x pneumatic horizontal clamps (KD 350 PS)
- 2x manual horizontal clamps

OPTIONAL ACCESSORIES

- MKN 300 length stop-left (3m)
- MKN 300 length stop-right (3m)
- DKN 302 length stop-right (3m)
- DKN 602 length stop-right (6m)
- Spare saw blade, Ø350 mm

GENEL ÖZELLİKLER

- 45°- 30°- 22.5 - 15°- 0° açılarda sağ ve sol yönde susta ile kesim
- 45° sol - 45° sağ ara derecelerde hassas kesim
- Alüminyumdan imal edilmiş makine gövdesi ve çelik sacdan üretilmiş makine sehпасı
- İstenilen açılara kolay ayarlanabilir mekanik altyapı
- Sağlam yay sistemi ve koruyucu siper

STANDART AKSESUARLAR

- Makine sehпасı
- Hava tabancası (KD 350 PS)
- Testere soğutma sistemi (KD 350 PS)
- 2x pnömatik yatay mengene (KD 350 PS)
- 2x manuel yatay mengene

OPSİYONEL AKSESUARLAR

- MKN 300 konveyör-sol (3m)
- MKN 300 konveyör-sağ (3m)
- DKN 302 konveyör-sağ (3m)
- DKN 602 konveyör-sağ (6m)
- Yedek testere bıçağı, Ø350mm



KD 350 M

MITER SAW MACHINE
DERECELİ KESME MAKİNESİ

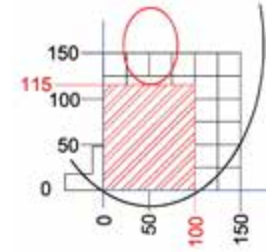
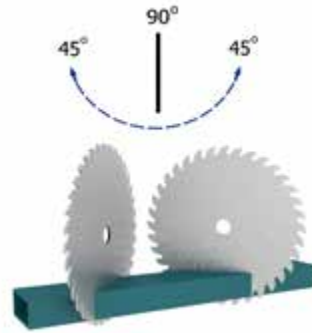

45° : 100 x 115 mm

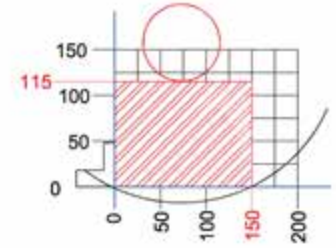

90° : 150 x 115 mm

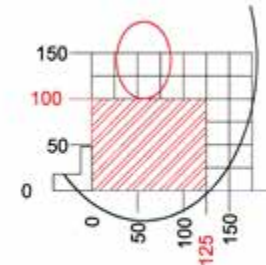

45° : 125 x 100 mm

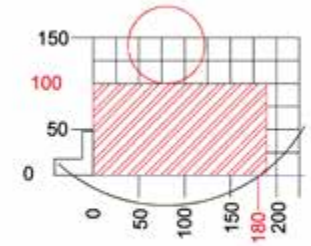

90° : 180 x 100 mm

			Bar	Air Cons.		WxLxH cm
2.2 kW 400V AC 3P PE 50-60 Hz.	D: Ø350 mm d: Ø30/32 mm	2.900 RPM	-	-	82x76x78.5	69
						86

GENERAL FEATURES

- Location points at 45° - 30° - 22,5° - 15° - 0° both left and right
- Pivoting range from 45° left to 45° right infinitely adjustable
- Aluminium construction of the body that is strong and lasting
- Robust mechanical construction enables the ease of adjustment for the requested cutting angles
- Strong spring system and protective shield

STANDARD ACCESSORIES

- Ø350 mm saw blade
- 2x manual horizontal clamps

OPTIONAL ACCESSORIES

- Machine stand
- MKN 300 roller conveyor (3m)
- Spare saw blade, Ø350 mm

GENEL ÖZELLİKLER

- 45° - 30° - 22,5° - 15° - 0° açılarda sağ ve sol yönde susta ile kesim
- 45° sol - 45° sağ ara derecelerde hassas kesim
- Alüminyumdan imal edilmiş uzun ömürlü ve dayanıklı makine gövdesi
- İstenilen açılara kolay ayarlanabilir mekanik altyapı
- Sağlam yay sistemi ve koruyucu siper

STANDART AKSESUARLAR

- Ø350 mm testere
- 2x manuel yatay mengene

OPSİYONEL AKSESUARLAR

- Makine sehpası
- MKN 300 konveyör (3m)
- Yedek Ø350 mm testere





**END MILLING AND COPY
ROUTING**





KERTME VE FREZELER

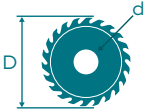

KM 215 S

SEMI AUTOMATIC END MILLING MACHINE
YARI OTOMATİK ORTA KAYIT ALIŞTIRMA MAKİNESİ



						
			Bar	Air Cons.		
1200W / 2A 400V AC 3P PE 50-60 Hz,	Dmax: Ø160mm d: Ø30mm	3.000 RPM	6-8 Bar	24 L/min.	42x83.5x120	99 120

GENERAL FEATURES

- High quality end-milling operations thanks to the hydro-pneumatic system
- Quick tool change system
- Adjustable support system to four different profiles
- Safety operations with safety guard
- End milling of PVC mullions between 45° and 90°
- Storage place for spare tools
- Fixing the workpiece firmly thanks to the vertical and horizontal clamps
- Practical cutter adjustment by means of the spacer parts
- Robust machine stand
- Profile clamping capacity: H: 160 x W: 225 mm
- Maximum end-milling capacity: H: 90 x W: 225 mm
- Maximum cutter diameter: Ø160 x 30 mm

STANDARD ACCESSORIES

- Spray tool lubrication system
- 1x pneumatic vertical clamp
- 1x pneumatic horizontal clamp
- Air gun

OPTIONAL ACCESSORIES

- Milling cutter sets according to the customer profiles
- MKN 100 length stop (1m)
- Spare mandrel & shim set for d: Ø30 mm cutters
- Extension kit for d: Ø30 cutters to increase the end-milling capacity to H:180 (special)
- Spare mandrel & shim set for d: 32 mm cutters
- Extension kit for d: Ø32 cutters to increase the end-milling capacity to H:180 (special)



GENEL ÖZELLİKLER

- Hidro-pnömatik freze hareketi ile kaliteli kertme operasyonları
- Seri bıçak değiştirme özelliği
- 4 farklı profile göre dayama sistemi
- Koruma kapağı ile güvenli çalışma
- PVC orta kayıt profillerin 45° - 90° arasında kertme işlemi
- Yedek takımlar için muhafaza yeri
- Pnömatik m mengeneler ile iş parçası güvenli olarak bağlanır
- Farklı kalınlıktaki şim ve pullar vasıtasıyla pratik kesme derinliği ayarlama
- Sağlam makine şasesi
- Mengene profil bağlama kapasitesi: H: 160 x W: 225 mm
- Maksimum kertme kapasitesi: H: 90 x W: 225 mm
- Maksimum testere çapı: Ø160 x Ø30 mm

STANDART AKSESUARLAR

- Püskürtmeli testere soğutma sistemi
- 1x pnömatik dikey mengene
- 1x pnömatik yatay mengene
- Hava tabancası

OPSİYONEL AKSESUARLAR

- Bıçak seti
- MKN 100 konveyör (1m)
- Yedek d: Ø30 mm kertme bıçakları için mandrel & şim seti
- Kertme kapasitesini H: 180 mm ye yükseltmek için mandrel set (d: Ø30 mm takımlar için) Y
- edek d: Ø32 mm kertme bıçakları için mandrel & şim seti
- Kertme kapasitesini H: 180 mm ye yükseltmek için mandrel set (d: Ø32 mm takımlar için)

KM 212

PORTABLE END MILLING MACHINE
PORTATİF ORTA KAYIT ALIŞTIRMA MAKİNESİ



800W 230V AC 1P N PE 50-60 Hz,	DMax: Ø120 mm d: Ø30mm	3.000 RPM	WxLxH cm 57x51x42	26 28

GENERAL FEATURES

- High quality end-milling operations by the manual operations
- Practical cutter adjustment thanks to the spacers
- Fixing the workpiece firmly thanks to the manual vertical and horizontal clamps
- Profile clamping capacity: H: 80 x W: 160 mm
- Max. end-milling capacity H: 80 x W: 160 mm
- Max. saw blade diameter: Ø120 x Ø30 mm

STANDARD ACCESSORIES

- 1x manual vertical clamp
- 1x manual horizontal clamp

OPTIONAL ACCESSORIES

- Machine stand
- Milling cutter set

GENEL ÖZELLİKLER

- Manuel freze hareketi ile kaliteli kертme operasyonları
- Farklı kalınlıktaki şım ve pullar vasıtası ile pratik kesme derinliđi ayarlama
- Manuel mngener ile iş parçası güvenli olarak bağlanır
- Mengene profil bağlama kapasitesi: H: 80 x W: 160 mm
- Maksimum kертme kapasitesi H: 80 x W: 160 mm
- Maksimum testere çapı: Ø120 x Ø30 mm

STANDART AKSESUARLAR

- 1x manuel dikey mengene
- 1x manuel yatay mengene

OPSİYONEL AKSESUARLAR





- Makine sehpası
- Bıçak seti

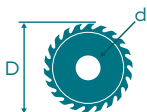

KM 211 S

MANUAL END MILLING MACHINE
MANUEL ORTA KAYIT ALIŖTIRMA MAKİNESİ



						
			Bar	Air Cons.		
1200W 400V AC 3P PE 50-60 Hz,	DMax: Ø170 mm d: Ø30 mm	3.000 RPM	6-8 Bar	14 L/min.	44x74x116	63
						61

GENERAL FEATURES

- High quality end-milling operations by the manual operation
- Safety operations with top guard
- Practical cutter adjustment thanks to the gap parts
- Fixing the workpiece firmly thanks to the pneumatic vertical and horizontal clamps
- Robust machine stand
- Profile clamping capacity: H: 160 x W: 150 mm
- Max. end-milling capacity: H: 90 x W: 150 mm
- Max. cutter diameter: Ø170 x Ø30 mm

STANDARD ACCESSORIES

- 1x pneumatic vertical clamp
- 1x pneumatic horizontal clamp
- Spray tool lubrication system
- Air gun

OPTIONAL ACCESSORIES

- Milling cutter set
- MKN 100 roller conveyor (1m)

GENEL ÖZELLİKLER

- Manuel freze hareketi ile kaliteli kertme operasyonları
- Koruma kapağı ile güvenli çalışma
- Farklı kalınlıktaki şim ve pullar vasıtası ile pratik kesme derinliği ayarlama
- Pnömatik mengener ile iş parçası güvenli olarak bağlanır
- Sağlam makine şasesi
- Mengene profil bağlama kapasitesi: H: 160 x W: 150 mm
- Maksimum kertme kapasitesi: H: 90 x W: 150 mm
- Maksimum testere çapı: Ø170 x Ø30 mm

STANDART AKSESUARLAR

- 1x pnömatik dikey mengene
- 1x pnömatik yatay mengene
- Püskürtmeli testere soğutma sistemi
- Hava tabancası

OPSİYONEL AKSESUARLAR







- Bıçak seti
- MKN 100 konveyör (1m)



FR 226 S

AUTOMATIC COPY ROUTER MACHINE
OTOMATİK KOPYA FREZE MAKİNESİ



						
			Bar	Air Cons.		
2x750 W 400V AC 3P PE 50-60 Hz,	14.000 / 900 RPM	Ø5xL80 mm	6-8	5 L/min.	85x56x147	107
						135

GENERAL FEATURES

- Opening locks, drilling handles, hinges, espagnolette and barrel holes etc. on PVC and aluminium profiles
- Hydro-pneumatic triple hole drilling mechanism
- Cast aluminium structure
- Corrosion proof bearing shaft
- Robust machine stand constructed from steel sheet
- Cutter tools

STANDARD ACCESSORIES

- Spray saw blade lubrication system
- Equipped with Ø5xL80 mm cutter bit for router mechanism
- Equipped with tools for triple drilling mechanism (2x Ø10mm + 1x Ø13mm)
- 2x left and right profile stops
- 2x pneumatic horizontal clamps
- Air gun

OPTIONAL ACCESSORIES

- Spare Ø5xL80 mm router bit
- Spare Ø10 mm cutter bit (for triple hole drill)
- Spare Ø13 mm cutter bit (for triple hole drill)
- Special copy templates
- MA 240 centring apparatus
- MK 150 length stop



GENEL ÖZELLİKLER

- Menteşe, üçlü kol yeri ve barel yuvası delikleri ile ıspanyolet ve kilit yuvası açma gibi birçok frezeleme ve delik delme işlemleri için kullanılır
- Dökme alüminyum gövde
- Krom kaplı paslanmaz yataklama milleri
- Hidro-pnömatik olarak çalışan üçlü kol yeri delme
- Çelik sacdan üretilmiş makine sehpası sistemi
- Tüm kesici takımlar monte edilmiştir

STANDART AKSESUARLAR

- Püskürtmeli takım soğutma sistemi
- Kopya freze işlemleri için Ø5xL80 mm freze ucu takılı olarak
- Üçlü kol yeri için matkap uçları takılı olarak (2x Ø10 + 1x Ø13 mm)
- 2x sol ve sağ profil dayama
- 2x pnömatik yatay mengene
- Hava tabancası

OPSİYONEL AKSESUARLAR

- Yedek Ø5xL80 mm freze ucu
- Yedek Ø10 mm freze ucu (üçlü kol yeri için)
- Yedek Ø13 mm freze ucu (üçlü kol yeri için)
- Özel kopyalama şablonu
- MA 240 ortalama aparatı
- MKN 150 konveyör









FR 223 - FR 223 S

PORTABLE TEMPLATE COPY ROUTER
PORTATİF KOPYA FREZE MAKİNESİ



*The machine above is FR 223 S.
*Resimde görülen makine FR 223 S'dir.

								
					Bar	Air Cons.		
FR 223	750 W 230V AC 1P N PE 50 Hz,	Ø5xL60 mm	14,000 RPM	x=270 mm y=110 mm z=110 mm	-	-	59x52x64.5	42 48
FR 223 S	750 W 230V AC 1P N PE 50 Hz,	Ø5xL60 mm	14,000 RPM	x=270 mm y=110 mm z=110 mm	6-8 Bar	-	59x56x65	46 48

GENERAL FEATURES

- Opening locks, drilling handles, hinges, espagnolette and barrel holes etc. on PVC and aluminum profiles
- Ergonomic handle for ease of operation
- Cast aluminum structure
- Corrosion proof bearing shaft
- Clamping capacity: W: 140
- Chrome electroplated copy template
- Two pcs. of tracer pins
- Equipped with Ø5xL60 mm router bit
- Working capacity: X: 270, Y: 110, Z: 110 mm

STANDARD ACCESSORIES

- Ø5 x L60 mm router bit
- 2x left and right profile stops
- 2x manual horizontal clamps
- Copy template
- Electrically working spray cooling systems (FR 223 S)

OPTIONAL ACCESSORIES

- Electrically working spray cooling systems (FR 223 S)
- MS machine stand kit
- Spare Ø5xL60 mm router bit
- Special copy templates
- MKN 150 roller conveyor

GENEL ÖZELLİKLER

- Menteşe, kol yeri ve barel yuvası delikleri ile ispanyolet ve kilit yuvası açma gibi birçok frezeleme ve delik delme işlemleri için kullanılır
- Ergonomik kullanma kolu
- Dökme alüminyum gövde
- Krom kaplı paslanmaz yataklama milleri
- Bağlanabilir profil genişliği: W: 140
- Kaplamalı saç metal şablon
- 2 adet izleme pimi
- Ø5xL60 mm freze ucu monte edilmiş olarak
- Çalışma kapasitesi: X: 270 - Y: 110 - Z: 110 mm

STANDART AKSESUARLAR

- Ø5 x L60 mm freze ucu
- 2x sol ve sağ profil dayama
- 2x yatay manuel mengene
- Kopya şablonu
- Elektrikli takım soğutma sistemi

OPSİYONEL AKSESUARLAR

- Elektrikli takım soğutma sistemi (FR 223 S)
- MS model makine sehпасı
- Yedek Ø5 mm freze ucu
- Özel kopyalama şablonu
- MKN 150 konveyör



FR 222

PORTABLE TEMPLATE COPY ROUTER
PORTATİF KOPYA FREZE MAKİNESİ



1200W 230V AC 1P N PE 50-60 Hz,	ø5xL60 mm	27000 RPM	x=245 mm y=120 mm z=80 mm	WxLxH cm 60x54x48	28 30

GENERAL FEATURES

- Opening locks, drilling handles, hinges, espagnolette holes etc. on PVC and aluminium profiles
- Cast aluminium structure
- Corrosion proof bearing shaft
- Electroplated copy template
- Equipped with Ø5 router bit

STANDARD ACCESSORIES

- Equipped with Ø5 x L60 mm router bit
- 2x left and right profile stops
- 2x horizontal clamps

OPTIONAL ACCESSORIES

- Spare router bit
- Special copy template
- MS type of machine stand

GENEL ÖZELLİKLER

- Menteşe, kol yeri ve barel yuvası delikleri ile ispanyolet ve kilit yuvası açma gibi birçok frezeleme ve delik delme işlemleri için kullanılır
- Dökme alüminyum gövde
- Krom kaplı paslanmaz yataklama milleri
- Kaplamalı saç metal şablon
- Ø5 freze ucu monte edilmiş olarak

STANDART AKSESUARLAR

- Ø5 x L60 mm freze ucu takılı olarak
- 2x sol ve sağ profil dayama
- 2x yatay manuel mengene

OPSİYONEL AKSESUARLAR

- Yedek freze ucu
- Özel kopyalama şablonu
- MS model makine sehpa



FR 221 S

PNEUMATIC TEMPLATE COPY ROUTER
PNÖMATİK KOPYA FREZE MAKİNESİ



750 W 400V AC 3P PE 50-60 Hz,	Ø5 x L60 mm	14.000 RPM	X: 270 mm Y: 110 mm Z: 130 mm	Bar	Air Cons.	WxLxH cm	73
				6-8 Bar	5 L/min.	55x242.5x133.5	103

GENERAL FEATURES

- Opening locks, drilling handles, hinges, espagnolette and barrel holes etc. on PVC and aluminium profiles
- Cast aluminium structure
- Corrosion proof bearing shaft
- Robust machine stand constructed from steel sheet
- Electroplated copy template
- 2x tracer pins
- Ø5 x L60 router bit included
- Clamping capacity: Wmax: 130, Wmin: 10, Hmax: 130, Hmin: 20 mm

STANDARD ACCESSORIES

- Spray tool lubrication system
- Ø5 x L60 mm of router bit
- 2x left and right profile stops
- 2x pneumatic horizontal clamps
- MKN 300 roller conveyor
- Air gun

OPTIONAL ACCESSORIES

- Spare Ø5 x L60 router bits
- Special copy templates
- MA 240 centring apparatus
- MKN 150 roller conveyor

GENEL ÖZELLİKLER

- Menteşe, kol yeri ve barel yuvası delikleri ile ispanyolet ve kilit yuvası açma gibi birçok frezeleme ve delik delme işlemleri için kullanılır
- Dökme alüminyum gövde
- Krom kaplı paslanmaz yataklama milleri
- Çelik sacdan üretilmiş makine sehpa
- Kaplamalı sac metal şablon
- 2x manuel izleyici pim
- Ø5 x L60 kesici takım monte edilmiş
- Bağlanabilir profil ölçüleri: Wmaks: 130, Wmin: 10, Hmaks: 130, Hmin: 20 mm

STANDART AKSESUARLAR

- Sprey takım soğutma sistemi
- Ø5 x L60 mm freze ucu
- 2x sol ve sağ profil dayama
- 2x pnömomatik yatay mengene
- MKN 300 konveyör
- Hava tabancası

OPSİYONEL AKSESUARLAR







- Yedek Ø5 x L60 mm freze ucu
- Özel kopyalama şablonu
- MA 240 ortalama aparatı
- MKN 150 konveyör



ST 264

AUTOMATIC PVC WATER SLOT MACHINE
OTOMATİK PVC SU TAHLİYE MAKİNESİ



						
3x0,55 kW 230V AC 1P N PE 50 Hz,	18.000 RPM	ø5xL80 / ø5xL60	Bar	Air Cons.	WxLxH cm	KG
			6-8 Bar	19 L/min.	73x61x130	78 116

GENERAL FEATURES

- Water slot opening process on PVC profiles is completed pneumatically
- Driller motors work separately in tree axis or two motors positioned in different axis work at the same time
- Practical adjustment of water slot length and depth by means of the stoppers
- Speed-adjustable pneumatically controlled motor movement
- 2x pneumatic clamps ensure precise machining of the profile
- Drilling starts automatically with the push of a button
- Axis misalignments in profiles are adjusted pneumatically with the movable table
- Motor selection through the switches
- PLC control system
- Maximum profile dimension: H: 115 x W: 100 mm

STANDARD ACCESSORIES

- Equipped with milling cutters, Ø5 x L80 and Ø5 x L60 mm
- Service keys
- Air gun

OPTIONAL ACCESSORIES

- Spare cutter bits Ø5 x L60 mm
- Spare cutter bits Ø5 x L80 mm

GENEL ÖZELLİKLER

- Su tahliye kanalı açma işlemi pnömatik olarak tamamlanır
- Üç eksen de tek tek veya iki eksen de aynı anda su tahliye kanalı açabilme
- Dayamalar sayesinde su tahliye kanalı boyu ve derinliği pratik olarak ayarlanır
- Hızı ayarlanabilir pnömatik kontrollü motor hareketi
- 2x pnömatik mgeneler profilin hassas olarak işlenmesini sağlar
- Tek butona basarak delme işlemi otomatik olarak başlatılır
- Hareketli tabla ile profillerdeki eksen kaçıklıkları pnömatik olarak ayarlanır
- Butonlar ile motor seçimi
- PLC kontrol sistemi
- Maksimum profil ölçüleri H: 115 x W: 100 mm

STANDART AKSESUARLAR

- Ø5 x L80 ve Ø5 x L60 mm freze uçları
- Servis anahtarı
- Hava tabancası

OPSIYONEL AKSESUARLAR







- Yedek Ø5xL60 mm kesici takımlar
- Yedek Ø5xL80 mm kesici takımlar

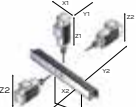

CRM 250 S

3 SPINDLE COPY ROUTER MACHINE
3 MOTORLU KOPYA FREZE MAKİNESİ



							
				Bar	Air Cons.		
3.3 kW 230V AC 1P+N+PE 50-60 Hz,	12.000 RPM	Ø10xL100/ 2xØ5xL100	x1,x2: 650,350 y1,y2: 180,230 z1,z2: 170,150	6-8 Bar	24 L/min.	126x290x187	318 373

GENERAL FEATURES

- Copy router with 1x vertical and 2x horizontal spindle motors
- Designed to perform the operations quickly and precisely on 3 sides of the aluminium profile without releasing
- Pneumatic 2x horizontal and 2x vertical clamps
- Horizontal and vertical pneumatic tracers with 3 different diameters Ø5, Ø8, Ø10 mm
- Horizontal & vertical templates including standart figures positioned vertically and horizontally
- High precision bearing mechanism, gas shock absorbers and ergonomic arm design that facilitate operations
- 1 meter of roller tables positioned at the right and left sides
- Manually adjustable profile stops placed on the right and left, allows the work piece to be positioned properly in the machine
- Spray tool cooling system
- Max. clamping capacity W: 200 mm H: 150 mm

STANDARD ACCESSORIES

- Equipped with Ø5 x L100 mm and Ø10 x L100 mm
- 2x profile stops both left and right
- Spray tool lubrication system
- 2x pneumatic horizontal clamps
- 2x pneumatic vertical clamps
- Air gun

OPTIONAL ACCESSORIES

- Spare cutter bits with Ø5 x L100 mm (for copy routing operations)
- Spare cutter bits with Ø10 x L100 mm (for copy routing operations)
- Spare collets for Ø5 mm of cutter bit
- Spare collets for Ø10 mm of cutter bit
- Special templates



GENEL ÖZELLİKLER

- 1x dikey ve 2x yatay kopya freze motoru mevcuttur
- Pofilleri çevirmeden 3 tarafını hızlı ve hassas olarak işleyebilmektedir.
- 2x dikey ve 2x yatay olmak üzere 4 adet pnömatrik mengene bulunmaktadır
- Yatay ve dikey şablon izleyici uçlar pnömatrik olup Ø5, Ø8 ve Ø10 olarak 3 farklı çapları mevcuttur
- Yatay ve dikey olarak konumlanmış standart operasyonları içeren yatay ve dikey şablonları
- Operasyonları kolaylaştıran yüksek hassasiyetli yataklama sistemi, gaz amortisörler ve ergonomik kol tasarımı
- Sağ ve sol tarafta 1 metre uzunluğunda konveyör tabla
- Manuel olarak ayarlanabilen, dayama sistemi, sağ ve sol konveyörde cetvel mevcuttur
- Sprey takım soğutma sistemi
- Maks. mengene kapasitesi G: 200 mm Y: 150 mm

STANDART AKSESUARLAR

- Tüm freze uçları takılı olarak 1x Ø5 x L100 mm ve 2x Ø10 x L100 mm
- 2x profil dayama sağ ve sol tarafta
- Püskürtmeli freze takım soğutma sistemi
- 2x pnömatrik yatay mengene
- 2x pnömatrik dikey mengene
- Hava tabancası

OPSİYONEL AKSESUARLAR

- Yedek Ø5 x L100 mm freze ucu (kopya freze işlemleri için)
- Yedek Ø10 x L100 mm freze freze ucu (kopya freze işlemleri için)
- Yedek Ø5 mm freze için takım tutucu pens
- Yedek Ø10 mm freze için takım tutucu pens
- Özel kopyalama şablonları

CRM 201 S

TEMPLATE COPY ROUTER MACHINE WITH TRIPLE
HOLE & WATER SLOT DRILLING

KOPYA FREZE, ÜÇLÜ KOL YERİ VE SU TAHLİYE MAKİNESİ

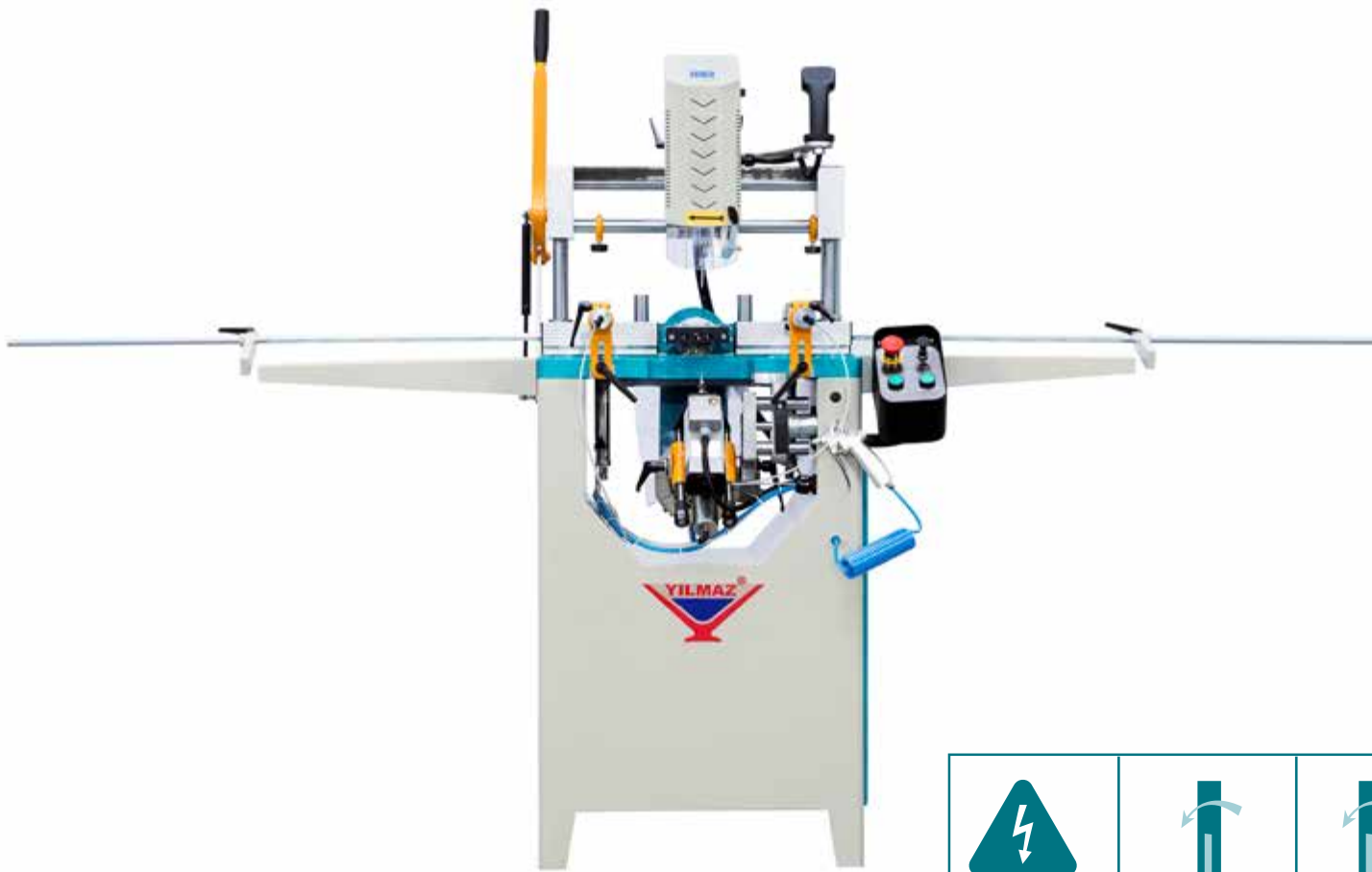

2.2 kW 230V AC 1P 50-60 Hz,	900 RPM 18.000 RPM	Ø5xL60/ Ø5xL80	X: 300 mm Y: 120 mm Z: 130 mm	Bar Air Cons.	WxLxH cm	KG
				6-8 Bar 24 L/min.	70.5x254x156.5	132 170

GENERAL FEATURES

- Copy mechanism operates manually and the figures on the template are machined at 1:1 ratio
- The aluminium profiles up to 3 mm of wall thickness can be machined with a strong spindle motor
- The cutting fluid controlled with a joystick is sprayed to the milling spot
- Slots in varied lengths and widths can be opened without using the copy milling template
- The length of the water drain slot is adjustable on the template
- Copy milling motor is directly controlled via joystick
- Reference stops at 2 sides of the milling machine
- Standard equipped with inlet-outlet profile supports
- Ergonomic hand control unit
- On the horizontal axis there is triple hole drilling mechanism
- Pneumatically working water slot opening system
- Equipped with whole cutter bits

STANDARD ACCESSORIES

- Equipped with tools for copy routing and water drain operations (1x Ø5 x L80 mm and 1x Ø5 x L60 mm)
- Equipped with tools for triple drilling mechanism (2x Ø10 mm, 1x Ø13 mm)
- Spray tool lubrication system
- 2x profile stops both left and right
- 2x horizontal clamps
- 2x vertical clamps
- Air gun

OPTIONAL ACCESSORIES

- Spare Ø10 mm cutter bit (for triple drilling operations)
- Spare Ø13 mm cutter bit (for triple drilling operations)
- Spare Ø5xL80 mm cutter bit (for copy routing operations)
- Spare Ø5xL60 mm cutter bit (for water drain operations)
- Spare collets for Ø5 mm of cutter bit
- Special copy templates



GENEL ÖZELLİKLER

- Kopya tertibatı manuel olarak çalışır ve şablon üzerindeki şekiller 1:1 oranında işlenir
- 3 mm kalınlığa kadar alüminyum profiller güçlü spindle motoru ile rahatlıkla işlenebilir
- Joystick ile kumanda edilen kesme sıvısı freze işleme noktasına püskürtülür
- Kopya freze şablonu kullanılmadan değişik boy ve genişlikte kanallar açılabilir
- Kopya şablonu üzerindeki su tahliye kanal boyu ayarlanabilir özelliktedir
- Kopya freze motoru direk olarak kumanda kolu üzerinden kontrol edilmektedir
- Kopya frezenin 2 tarafında dayama mili mevcuttur
- Standart olarak verilen giriş-çıkışta profil destekler mevcuttur
- Ergonomik el kumanda ünitesi
- Yatay ekseninde üçlü kol yeri delme sistemi mevcuttur
- Su tahliye kanalı açma hareketi pnömatik olarak tamamlanır
- Tüm takımlar monte edilmiş olarak

STANDART AKSESUARLAR

- Kopya freze ve su tahliye için 1x Ø5 x L80 mm ve 1x Ø5 x L 60 mm freze ucu takılı
- Üçlü kol yeri için matkap uçları takılı olarak (2x Ø10mm, 1x Ø13mm)
- Püskürtmeli freze takım soğutma sistemi
- 2x profil dayama sağ ve sol tarafta
- 2x pnömatik yatay mengene
- 2x pnömatik dikey mengene
- Hava tabancası







OPSİYONEL AKSESUARLAR

- İlave Ø10 mm freze ucu (üçlü delik delme işlemleri için)
- İlave Ø13 mm freze ucu (üçlü delik delme işlemleri için)
- İlave Ø5xL80 mm freze ucu (kopya freze işlemleri için)
- İlave Ø5xL60 mm freze ucu (su tahliye işlemleri için)
- İlave Ø5 mm freze için takım tutucu pens
- Özel kopyalama şablonu

NCR 300

4 AXIS NUMERICAL CONTROLLED NC ROUTER MACHINE
4 EKSEN NUMERİK KONTROLLÜ NC FREZE MAKİNESİ



							
				Bar	Air Cons.		
5.5 kW/20 A 400V AC 3P PE 50-60 Hz	Ø8 x L120 mm	12.000 RPM	X: 300 Y: 120 Z: 115	6-8 Bar	110 L/min.	163.5x281x218	520 600

GENERAL FEATURES

- Designed for the daily operations on PVC, aluminium and low alloy materials to machine four surfaces of them at the same time
- Equipped with servo-controlled table mechanism to stop the turning table and machining the profiles in angles among the 0°/90°/180°/270°
- Machinability of profiles up to 2.750 mm of length by multi pop-up length stops
- Machining capacity: X: 300 mm, Y: 120 mm, Z: 115 mm
- Profile clamping width (Wmax / Wmin): 120 x 30 mm
- Profile clamping height (Hmax / Hmin): 115 x 30 mm
- Profile clamping length: (Lmax / L min): 2.750 x 400 mm
- Electronic and pneumatic braking system for detaining falls of head and table
- ER 16 tool collet
- 2.2 kW, 3P, 400V Spindle (12.000 RPM)
- PLC control system

STANDARD ACCESSORIES

- Equipped with Ø8 x L120 mm cutter bit
- 2x horizontal and 2x vertical pneumatic clamps
- Spray tool lubrication system
- Multiple left and right profile stops
- Service spanners (22 mm)
- Collet wrench
- LED lighting equipment
- Extending parts for clamps
- Profile centring apparatus
- Air gun

OPTIONAL ACCESSORIES

- Spare Ø8 x L120 carbide, single lip cutter bits
- Spare Ø8 x L63 carbide, single lip cutter bits
- Spare Ø8 x L120 carbide, double lip cutter bits
- Spare collets for Ø8 mm of cutter bits



GENEL ÖZELLİKLER

- PVC, Alüminyum ve düşük alaşımlı malzemelerin 4 yüzeyini aynı anda işlemek amacı ile günlük operasyonlar için dizayn edilmiştir.
- Profillerin 4 yüzeyini -0°/90°/180°/270° açı aralığında işleyebilen servo motor kontrollü tabla mekanizması
- Çoklu dayama sistemi ile profilleri kaydırarak 2.750 mm boya kadar işleyebilme özelliği
- İşleme kapasitesi: (X) 300 mm, (Y) 120 mm, (Z) 115 mm
- Bağlanabilir profil genişliği (Wmaks / Wmin): 120 x 30 mm
- Bağlanabilir profil yüksekliği (Hmaks / Hmin): 115 x 30 mm
- Bağlanabilir profil boyu: (Lmaks / Lmin): 2.750 x 400 mm
- Kafa ve tabla düşmelerine karşılık elektronik ve pnömatik frenleme sistemi
- ER 16 takım tutucu pens
- 2.2 kW, 3P, 400V freze motoru (12.000 RPM)
- PLC kontrol sistemi

STANDART AKSESUARLAR

- Ø8 x L120 mm freze ucu takılı olarak
- 2x yatay ve 2x pnömatik dikey mengene
- Püskürtmeli freze takım soğutma sistemi
- Sağ ve sol tarafta çoklu profil dayama sistemi
- Servis anahtarı (22 mm)
- Pens anahtarı
- LED aydınlatma sistemi
- Mengeneler için uzatma parçaları
- Profil merkezleme aparatı
- Hava tabancası

OPSİYONEL AKSESUARLAR

- Yedek Ø8 x L120-Z1 Karbür tek ağızlı freze
- Yedek Ø8 x L63-Z1 Karbür tek ağız freze
- Yedek Ø8 x L63 Z=2 Karbür iki ağız freze
- Yedek ER16 Ø8 takım tutucu pens, Ø8 freze için

WELDING AND CLEANING MACHINES



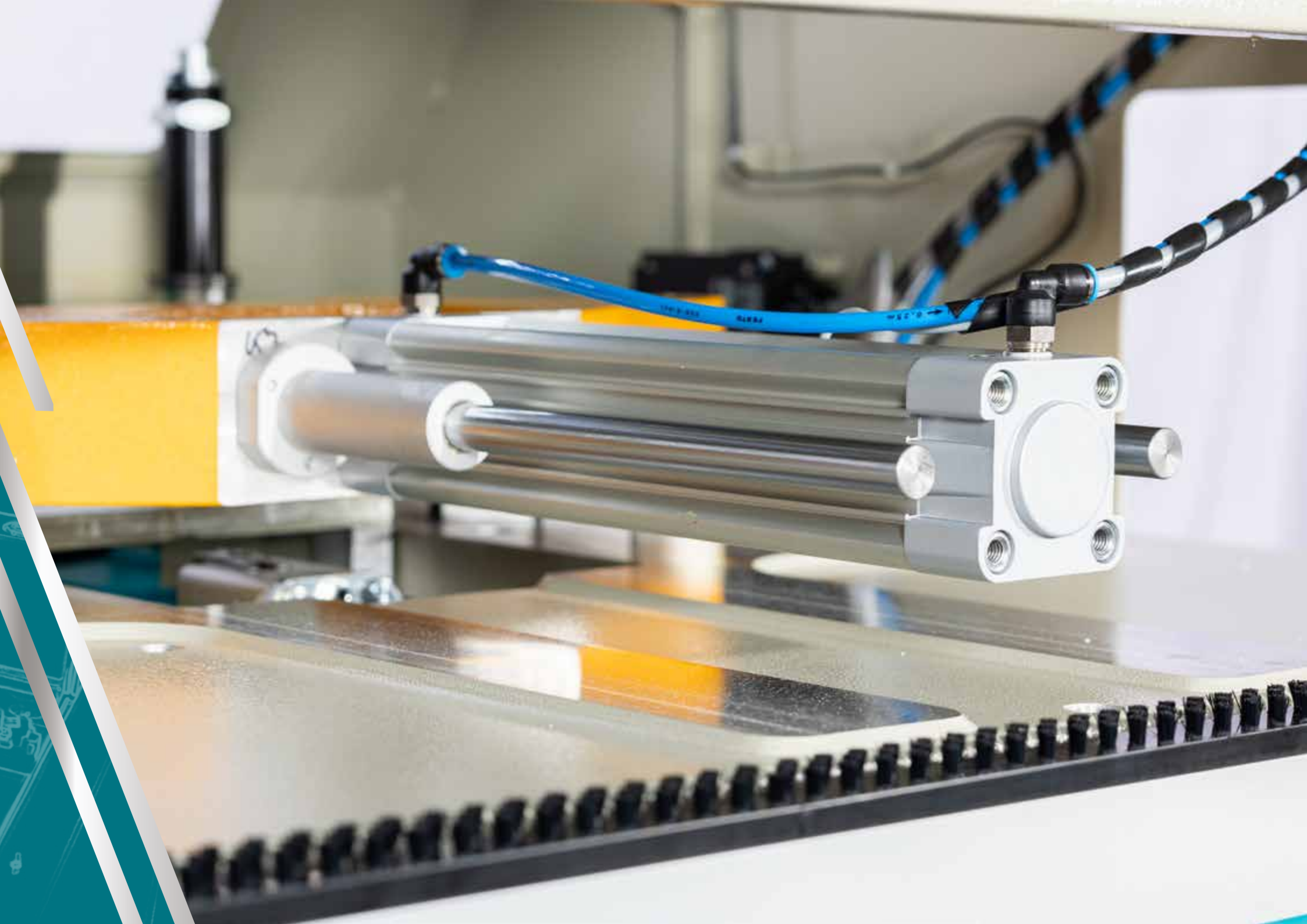

KAYNAK VE ÇAPAK ALMA MAKİNELERİ

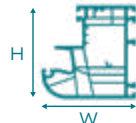

TK 505

SINGLE CORNER PVC WELDING MACHINE
PVC TEK KÖŞE KAYNAK MAKİNESİ



					
		Bar	Air Cons.		
1,5 kW 230V AC P N PE 50-60 Hz,	Hmax: 180 mm Hmin: 30 mm Wmax: 130 mm Wmin: 30 mm α : 30° - 180°	6-8	20 L/min.	74.5x194.5x155.5	126
		Bar			158

GENERAL FEATURES

- All parameters such as melting and welding time, welding pressure are set independently
- User friendly with the features of cleaning the plates and replacing teflon very easily and quickly
- Thanks to the profile support arms, long profiles can be easily welded
- Practical adjustment of standard (2.0 mm) or seamless (0.2 mm) welding options manually
- Profile support arms are supplied as standard in both directions
- Adjusting the heat between 0 - 300°C by means of the electronic thermocouple
- Saving of time thanks to the practical mold change feature
- Automatically start and finish the welding cycle
- Enable the welding of all angles between 30° - 180° infinitely adjustable
- Clamping the profiles separately via foot pedal
- Maximum H: 180 mm welding capability

STANDARD ACCESSORIES

- Electrical foot pedal
- Profile support arms

OPTIONAL ACCESSORIES

- Special welding molds

GENEL ÖZELLİKLER

- Eritme ve yapıştırma zamanı ile kaynak basıncı gibi tüm parametreler bağımsız olarak ayarlanabilmektedir
- Plakaların temizlenmesi ve teflon'un çok kolay ve hızlı değiştirilmesi nedeni ile kullanıcı dostudur
- Profil destek kolları sayesinde uzun profiller düzgün ve kolay olarak kaynak yapılabilmektedir
- Standart (2.0 mm) veya sıfır (0.2 mm) kaynak kalınlığına manuel geçiş özelliği
- Her iki yönde olmak üzere profil destek kolları standart olarak verilmektedir
- Elektronik termokupl sayesinde 0° - 300°C arasında ısıyı ayarlama özelliği
- Pratik kaynak kalıbı değiştirme sistemi ile zaman kaybı önlenir
- Kaynak işlemini otomatik olarak başlatma ve bitirme özelliği
- 30° - 180° açı aralığında tüm açılarda hassas kaynak yapabilmek
- Ayak pedalı ile profilleri ayrı ayrı sabitleme özelliği
- Maksimum H: 180 mm kaynak yapabilmek özelliği

STANDART AKSESUARLAR

- Elektrik ayak kumanda pedalı
- Profil dayama kolları

OPSİYONEL AKSESUARLAR

- Özel kaynak kalıpları



TK 503

SINGLE CORNER PVC WELDING MACHINE
PVC TEK KÖŞE KAYNAK MAKİNESİ



		Bar	Air Cons.		
1,5 kW 230V AC P N PE 50-60 Hz,	Hmax: 165 mm Hmin: 30 mm Wmax: 130 mm Wmin: 30 mm α : 30° - 180°	6-8 Bar	20 L/min.	60x191.5x140	113 128

GENERAL FEATURES

- All parameters such as melting time, welding time and welding pressure are set independently
- User friendly with the features of cleaning the plates and replacing teflon very easily and quickly
- Practical adjustment of standard (2.0 mm) or seamless (0.2 mm) welding options manually
- Thanks to the profile support arms, long profiles can be easily welded
- Profile support arms are supplied as standard in both directions
- Adjusting the heat between 0 - 300°C by means of the electronic thermostat
- Saving of time thanks to the practical mold change feature
- Enable the welding of all angles between 30° - 180° infinitely adjustable
- Automatically start and finish the welding cycle
- Welding possibility of profiles up to H:165 mm of high
- Clamping the profiles separately via foot pedal
- Portable machine stand

STANDARD ACCESSORIES

- Electrical foot pedal
- Profile support arms

OPTIONAL ACCESSORIES

- Special welding molds

GENEL ÖZELLİKLER

- Eritme ve yapıştırma zamanı ile kaynak basıncı gibi tüm parametreler bağımsız olarak ayarlanabilmektedir
- Plakaların temizlenmesi ve teflonun çok kolay ve hızlı değiştirilmesi özelliği ile kullanıcı dostudur
- Standart (2.0 mm) veya sıfır (0.2 mm) kaynak kalınlığına göre pratik manuel ayarlama
- Profil destek kolları sayesinde uzun profiller kolaylıkla kaynak yapılabilmektedir
- Her iki yönde olmak üzere profil destek kolları standart olarak verilmektedir
- Elektronik termokupl sayesinde 0° - 300°C arasında ısıyı ayarlama özelliği
- Pratik kaynak kalıbı değiştirme sistemi ile zaman kaybı önlenir
- 30° - 180° açı aralığında tüm açılarda hassas kaynak yapabileme
- Kaynak işlemini otomatik olarak başlatma ve bitirme özelliği
- Maksimum H: 165 mm yüksekliğe kadar kaynak yapabileme özelliği
- Ayak pedalı ile profilleri sabitleme özelliği
- Portatif makine sehpası

STANDART AKSESUARLAR

- Elektrik ayak kumanda pedalı
- Profil dayama kolları

OPSİYONEL AKSESUARLAR





- Özel kaynak kalıpları

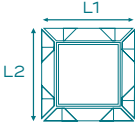
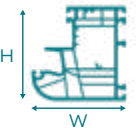

DK 540

FOUR CORNER PVC WELDING MACHINE
DÖRT KÖŞE KAYNAK MAKİNESİ



						
			Bar	Air Cons.		
8,4 kW 400V AC 3P N PE 50-60 Hz,	L1min: 400 mm L1max: 3.000 mm L2min: 400 mm L2max: 2.700 mm	Hmax: 180 mm Hmin: 30 mm Wmax: 130 mm Wmin: 30 mm	6-8	55 L/min.	515x450x150	1.690
			Bar			2.079

GENERAL FEATURES

- Fully automatic four corner welding of PVC window profiles at 90°
- Welding of a complete window frame or sash in one cycle
- All profile related welding parameters are individually programmable
- Parameters are set easily by means of 8" LCD colour touch screen
- Automatic line can be set by combining with Cooling Unite (SA 250), Corner Cleaning Machine (CNC 608-610), Rotating Robot (SA 260) and Window Buffer Station (SA 251)
- Automatically setting the standard (2.0 mm) or seamless (0.2 mm) welding options
- Long-period of teflon usage thanks to the teflon roller system
- Automatically discharging of the frames after welding operation
- Saving of time by means of practical mould change system
- Adjusting the heat between 0 - 300°C via electronic thermocouple
- Minimum welding measurement: 400 x 400 mm
- Maximum welding measurement: 3.100 x 2.700 mm
- Memory capacity to save up programs of 900 different profiles
- Operator safety barrier
- Barcode scanner

STANDARD ACCESSORIES

- 1 set of sash welding mould according to 70 mm of profile height
- 1 set of adaptor for frame profile
- Manual greasing pump

OPTIONAL ACCESSORIES

- Welding fixture set for lame sash
- Special welding moulds on demand
- CS 240 gasket pressing system
- SA 250 cooling unite



GENEL ÖZELLİKLER

- PVC profillerin 90° de tam otomatik olarak kaynak işlemlerini yapar
- Tek operasyonda PVC kasa ve kanat profillerin dört köşesini kaynatır
- Profil kaynağı ile ilgili tüm değişkenler kolaylıkla programlanabilmektedir
- Parametreler 8" dokunmatik renkli ekran vasıtası ile kolaylıkla set edilir
- Soğutma Ünitesi (SA 250), Çapak Alma (CNC 608-CNC 610), Döndürme Robotu (SA 260) ve Pencere Yedekleme Ünitesi (SA 251) ile birlikte otomatik olarak hat halinde kurulabilir
- (2 mm) veya sıfır (0.2 mm) kaynak aralığına göre otomatik olarak operasyon yapabilme özelliği
- Teflon sarma sistemi ile uzun süreli teflon kullanım özelliği
- Kaynak işleminden sonra otomatik olarak profillerin tahliye edilmesi
- Pratik kaynak kalıbı değiştirme sistemi ile zaman kayıpları önlenir
- Elektronik termokupl sayesinde 0°C - 300°C arasında ısıyı ayarlama özelliği
- Minimum çerçeve ölçüleri: 400 x 400 mm
- Maksimum çerçeve ölçüleri: 3.100 x 2.700 mm
- 900 adet profil için üretim hafıza kayıt imkanı
- Operatör güvenlik bariyeri
- Barkod okuyucu

STANDART AKSESUARLAR

- 1 set 70 mm yükseklikte profile göre kasa kalıbı
- 1 set kanat adaptörü
- Manuel yağlama pompası

OPSİYONEL AKSESUARLAR

- Topal kasa kaynak seti
- Talebe göre kaynak kalıpları
- CS 240 conta baskı sistemi
- SA 250 soğutma ünitesi

DK 502

DOUBLE CORNER PVC WELDING MACHINE
PVC ÇİFT KÖŞE KAYNAK MAKİNESİ



		Bar	Air Cons.		WxLxH cm
3 kW 230V AC 1P N PE 50-60 Hz,	Hmax: 180 mm Hmin: 30 mm Wmax: 140 mm Wmin: 30 mm α : 30° - 180°	6-8 Bar	180 L/min.	410x170x80	611 700

GENERAL FEATURES

- Fully automatic two corner welding of PVC window profiles at an angle of 90°
- Single head welding possibility
- Possibility of precise welding of profiles between 30°-180° on the left head
- All parameters such as melting and welding time, welding pressure are set on the control panel independently
- Continuous precision of welding quality by means of linear rails
- Welding of two corners of window frames or sash profiles are carried out in one cycle
- User friendly with practical teflon change feature by means of the roller system
- Saving of time by means of most practical mold change system in the market
- Capable of adjusting the clamp and welding pressure according to the profile type
- Adjusting the heat between 0-300°C via electronic thermostat
- Practical setting of standard (2 mm) or seamless (0.2 mm for free of flashes) welding options
- The movable right unit moves manually
- After clamping the profiles, the welding is carried out automatically
- The moveable right welding unit is equipped with a brake system
- For safety reasons, the clamp pistons operate with low pressure control system

STANDARD ACCESSORIES

- Equipped with 2x of support arms

OPTIONAL ACCESSORIES

- Special welding molds on demand

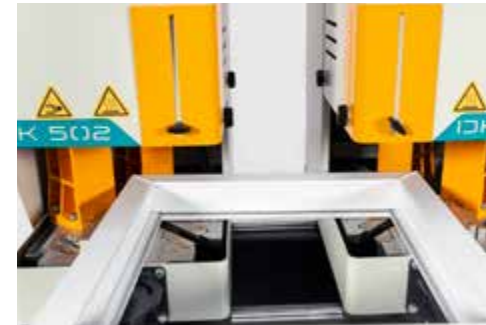
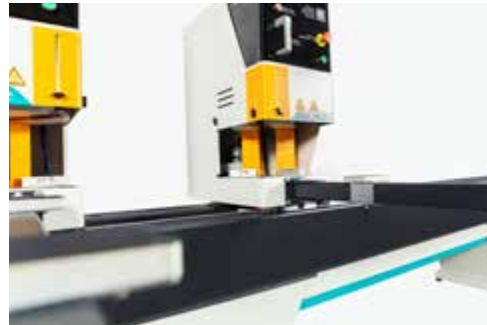
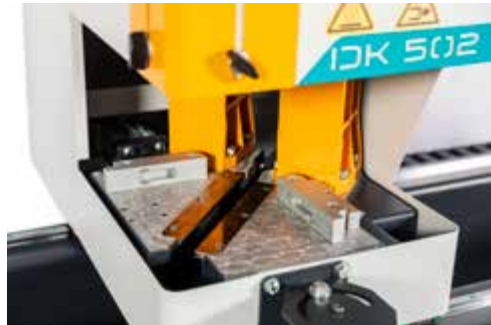

GENEL ÖZELLİKLER

- PVC profillerin 90° de otomatik olarak kaynak işlemlerini yapar
- Tek kafa kaynak yapabilme özelliği
- 30° - 180° açı aralığında sabit (sol) ünite üzerinde hassas kaynak özelliği
- Eritme ve yapıştırma zamanı, kaynak basıncı gibi tüm parametreler bağımsız olarak kontrol paneli üzerinden ayarlanabilmektedir
- Lineer yataklama mekanizması sayesinde hassas kaynak sağlanmaktadır
- Tek operasyonda PVC kasa ve kanat profillerinin iki köşesini kaynatır
- Pratik teflon sarma sistemi ve hızlı değiştirme özelliği ile kullanıcı dostudur
- Pratik kaynak kalıbı değiştirme sistemi sayesinde kayıp zamanlar önlenir
- Profil çeşidine göre mengene ve yapıştırma basınç ayarı yapabilme
- Elektronik termokupl sayesinde 0° - 300°C arasında ısıyı ayarlama özelliği
- Standart (2 mm) veya sıfır (0.2 mm) kaynak kalınlığına göre pratik olarak operasyon yapabilme özelliği
- Sağ kafa manuel olarak hareket ettirilir
- Profiller sabitlendikten sonra kaynak işlemi otomatik olarak başlar
- Hareketli sağ kaynak ünitesi üzerinde frenleme sistemi mevcuttur
- Emniyet açısından mengene pistonları düşük basınç kontrol sistemine göre çalışmaktadır

STANDART AKSESUARLAR

- 2x pencere destek profili







OPSİYONEL AKSESUARLAR

- Talebe göre özel kaynak kalıpları

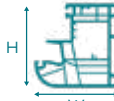
CA 603

PVC CORNER CLEANING MACHINE (4 CUTTERS)
PVC KÖŞE TEMİZLEME MAKİNESİ (4 BIÇAKLI)



							
				Bar	Air Cons.		
2.4 kW 400V AC 3P PE 50-60 Hz,	Hmax: 180 mm Hmin: 50 mm Wmax: 130 mm Wmin: 30 mm	Dmax: Ø210 mm d: Ø32 mm	3.000 RPM	6-8	48 L/min.	152.5x240.5x129.5	226
							273

GENERAL FEATURES

- High quality stripping and cleaning operations by means of the hydro-pneumatic system
- Processing capability for max. profile dimension: W: 130 - H: 180 mm
- Processing capability for min. profile dimension: W: 30 - H: 50 mm
- Min. outer frame sizes according to W: 30 and W: 60 mm of profile width L: 350 x L: 350 mm and L: 380 x L: 380 mm Stripping blade levels are adjustable according to laminated and unlaminated profiles
- Pneumatically working serial blade changing function that makes working easier
- Fixing the workpiece firmly by means of the vertical and horizontal clamps
- Stops automatically after stripping and cleaning operation
- PLC operation system
- Centring system to fit the profiles properly on the setsquare
- Robust machine stand
- Stripping blade levels are adjustable according to laminated and unlaminated profiles
- Processing capability of 4 different PVC profile
- 4 different cutter set can be mounted on both block

STANDARD ACCESSORIES

- Air gun
- Profile support table with brushed
- Special corner cleaning cutter set

OPTIONAL ACCESSORIES

- Cleaning cutter for colored profiles
- V type of cleaning cutter for white profiles

GENEL ZELLİKLER

- Hidro-pnömatik bıçak hareketi ile kaliteli temizleme operasyonları
- W: 130 - H: 180 mm maksimum profil ölçülerinde apak alma işlemi yapılabilmektedir
- W: 30-H: 50 mm min. profil ölçülerinde apak alma işlemi yapılabilmektedir
- W: 30 mm ve W: 60 mm genişlikteki profiller için minimum dış çerçeve ölçüsü L: 350 x L: 350 ve L: 380 x L: 380 mm dir
- Çalışmayı kolaylaştıran pnömatik sistem seri bıçak deęiştirme özellięi
- Pnömatik mengenerler ile iş parçası güvenli olarak bağlanır
- Operasyon sonrası otomatik motor stop özellięi
- PLC kontrol sistemi
- Profillerin gönyeye düzgün oturmasını sağlayan merkezleme sürücüsü
- Sağlam makine şasesi
- Bıçakların kesme derinlięi kaplamalı ve kaplamasız profillere göre ayarlanabilmesi
- 4 farklı PVC profile işleyebilme özellięi
- 4 set bıçak bloęa bağlayabilme özellięi

STANDART AKSESUARLAR

- Köşe temizleme bıçak seti
- Fıra kaplı profil destek tablası
- Hava tabancası

OPSİYONEL AKSESUARLAR

- Renkli profiller için temizleme bıçaęı
- Beyaz profiller için V temizleme bıçaęı



CA 601

SEMI-AUTOMATIC PVC CORNER CLEANING MACHINE
YARI-OTOMATİK PVC KÖŞE TEMİZLEME MAKİNESİ



1 kW 400V AC 3P PE 50-60 Hz,	Hmax: 180 mm Hmin: 30 mm Wmax: 130 mm Wmin: 30 mm	Dmax:Ø215 mm d:Ø32 mm	3.000 RPM	Bar Air Cons.	WxLxH cm	KG
				6-8 36 L/min.	1375x240.5x125.5	165 210

GENERAL FEATURES

- Min. inner and outer frame sizes according to W: 30 and W: 60 mm of profile width L: 350 x L: 350 mm and L: 380 x L: 380 mm
- High quality stripping and cleaning operations by means of the hydro-pneumatic system
- Stripping blade levels are adjustable according to laminated and unlaminated profiles
- Pneumatically working serial blade changing function that makes working easier
- Fixing the workpiece firmly by means of the vertical and horizontal clamps
- Processing capability for max. profile dimension: W: 130 - H: 180 mm
- Processing capability for min. profile dimension: W: 30 - H: 30 mm
- Centring system to fit the profiles properly on the setsquare
- Automatic start up feature when profile placed on the table
- Stops automatically after stripping and cleaning operation
- Single or multi cleaning operations can be processed
- Robust machine stand
- PLC control system

STANDARD ACCESSORIES

- Profile support table with brushed
- Air gun

OPTIONAL ACCESSORIES

- Special corner cleaning cutter set
- Cleaning cutter for colored profiles
- V type of cleaning cutter for white profiles

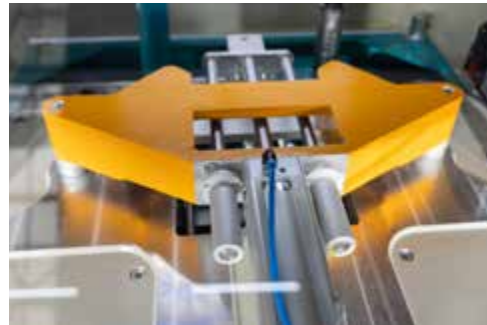

GENEL ZELLİKLER

- W: 30 mm ve W: 60 mm genişlikteki profiller için minimum dış çerçeve ölçüsü L: 350 x L: 350 ve L: 380 x L: 380 mm dir
- Hidro-pnömatik bıçak hareketi ile kaliteli temizleme operasyonları
- Kaplamalı veya kaplamasız profillere göre bıçakların kesme derinliğinin ayarlanabilmesi
- Çalışmayı kolaylaştıran pnömatik sistem seri bıçak deęiştirme özellięi
- Profillerin gönyeye düzgün oturmasını sağlayan merkezleme sürücüsü
- Pnömatik mengener ile iş parçası güvenli olarak bağlanır
- Maksimum profil ölçüleri: Wmax: 130 mm - Hmaks: 180 mm
- Minimum profil ölçüleri: Wmin: 30 mm - Hmin: 30 mm
- Profil yerleştirmede otomatik start alma özellięi
- Operasyon sonrası otomatik motor stop özellięi
- Temizleme operasyonları tek tek veya çoklu olarak çalıştırılabilmektedir
- Sağlam makine şasesi
- PLC kontrol sistemi

STANDART AKSESUARLAR

- Fırça kaplı profil destek tablası
- Hava tabancası





OPSİYONEL AKSESUARLAR

- Köşe temizleme bıçak seti
- Renkli profiller için temizleme bıçaęı
- Beyaz profiller için V temizleme bıçaęı

CNC 609 - CNC 611

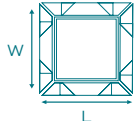
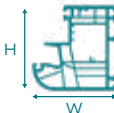
PVC CORNER CLEANING MACHINE (2-4 AXIS)
PVC KÖŞE TEMİZLEME MAKİNESİ (2-4 EKSEN)



								
					Bar	Air Cons.		
CNC 609	3 kW 400V AC 3P PE 50-60 Hz,	Wmin:400 mm Lmin:400 mm Wmax:2.200 mm Lmax: 2.200 mm	Hmax:180 mm Hmin:30 mm Wmax:130 mm Wmin:30 mm	D:Ø250 mm d:Ø30/32 mm	6-8	180 L/min.	231x240x177	680 790
CNC 611	3.85 kW 400V AC 3P PE 50-60 Hz,	Wmin:400 mm Lmin:400 mm Wmax:2.200 mm Lmax: 2.200 mm	Hmax:180 mm Hmin:30 mm Wmax:130 mm Wmin:30 mm	D:Ø250 mm d:Ø30/32 mm	6-8	180 L/min.	231x240x177	700 790

GENERAL FEATURES

- All unit parameters can be set independently according to the frames
- Automatic frame and sash profile recognition system
- Automatic line can be set by combining with Four Corner Welding Mach. (DK 541), Cooling Unit (SA 251) and Rotating Robot (SA 261) at a later date
- The upper and lower surfaces are cleaned with two separate cleaning units operating independently of each other (CNC 611)
- Memory capacity for 65.000 different profiles
- Windows based industrial PC and 15" LCD touch screen colour monitor
- Remote connection via internet and providing technical support
- Manual adjustment of feed rates on the control panel
- Transferring facility of the new programs via USB
- Portable touch screen control panel
- Low pressure control valve
- Automatic central lubrication system
- Phase control equipment
- Processing capacity with 210-230 window frames in 8 hours for CNC 609
- Processing capacity with 260-280 window frames in 8 hours for CNC 611

STANDARD ACCESSORIES

- Total of 11 tools, consisting of a cleaning saw, internal scraping blades and milling cutters
- Brushed window support table

OPTIONAL ACCESSORIES

- Line Harmonization Package (CNC 608 R)
- CNC 608-610 Asymmetric Window Sash Option (CNC 609)



GENEL ÖZELLİKLER

- Dört köşe kaynak (DK 540), Soğutma Ünitesi (SA 255), ve Döndürme Robot (SA 260) ile birlikte otomatik olarak hat halinde kurulabilir
- Birbirinden bağımsız olarak çalışan iki ayrı temizleme ünitesi ile alt ve üst yüzeylerin temizlenmesi işlemi yapılır (CNC 610)
- 8 saatlik çalışma diliminde 260-280 çerçeve çıkarma imkanı (CNC 610)
- 8 saatlik çalışma diliminde 210-230 çerçeve çıkarma imkanı (CNC 608)
- Windows tabanlı endüstriyel PC ve 15" dokunmatik renkli panel ekran
- Tüm parametreler ekranda bağımsız olarak ayarlanabilmektedir
- İnternet yolu ile uzaktan bağlanma ve teknik destek sağlama
- Çalışma sırasında ilerleme hızlarını ekran üzerinden kolaylıkla ayarlayabilme
- Kasa ve kanat profillerini otomatik olarak ayırabilme özelliği
- Yeni profiller için programların USB bellek ile kolaylıkla transfer edilebilme imkanı
- 65.000 adet profil hafıza kapasitesi
- Otomatik yağlama ve soğutma sistemi
- Hareket ettirilebilir kontrol paneli
- Şebeke faz kontrol sistemi
- Düşük basınç kontrol valfi

STANDART AKSESUARLAR

- Profil temizleme testeresi, iç kazıma bıçakları ve frezelerden oluşan 11 adet takımlik set
- Fırçalı pencere destek tablası

OPSİYONEL AKSESUARLAR



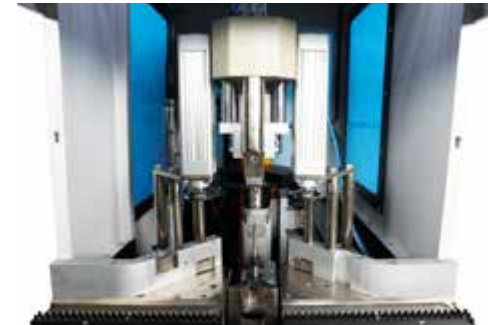

- Hatta Uyum Paketi (CNC 608 R)
- CNC 608-610 Asimetrik Kanat Opsiyonu (CNC 608)

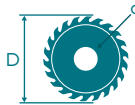

WGM 202

WINDOW GASKET MILLING MACHINE
PENCERE CONTASI FREZELEME MAKİNASI



						
3 kW 16A 380V 3P 50-60 Hz,	D:Ø30 mm	12.000 RPM	Bar	Air Cons.	WxLxH cm	160
			6-8	30 L/ min.	L:115 cm W: 100 cm H: 150 cm	

GENERAL FEATURES

- Machine prevents the protrusion issue of gaskets by milling gasket & profile set before the welding process
- Have 4 milling blades
- It has manual revolver with 6 stations for different profile systems
- Can mill single or double profile at the same time
- Can mill 2 gaskets in the sash profile and 2 gaskets in the base profile
- Ability to mill the middle gasket in frames with this type of gasket
- 7" touch screen panel

STANDARD ACCESSORIES

- 4x milling cutters installed
- Air gun

GENEL ÖZELLİKLER

- Makine, kaynak işleminden önce conta ve profil setini frezeleyerek contaların çıkıntı sorununu önler
- Dört adet frezeleme testeresi vardır.
- Farklı profiller için 6 istasyonlu manuel hafıza sistemi mevcuttur
- Tek veya çift aynı anda iki profil frezeleme işlemi yapar
- Kanat profilde 2 adet ve kasa profilde 2 adet contayı frezeleme yapabilir
- Orta contalı kasalarda orta contayı da frezeleme yapar
- 7" dokunmatik panel

STANDART AKSESUARLAR

- 4x freze bıçağı takılı olarak
- Hava tabancası

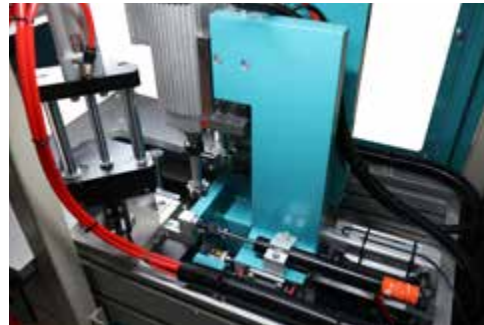









SCREWDRIVING
DESTEK SACI VIDALAMA

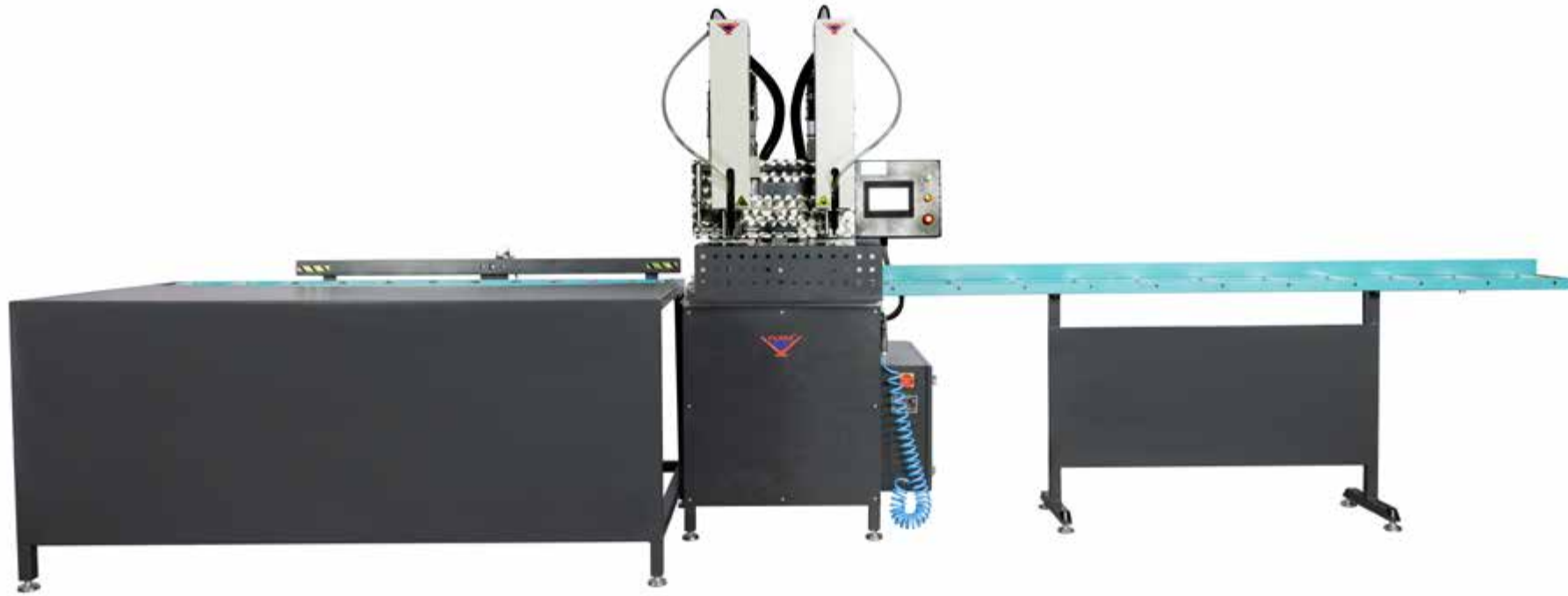

SM 206

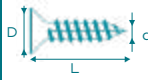
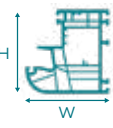
FULLY AUTOMATIC DOUBLE HEAD REINFORCEMENT STEEL SCREWDRIVER
TAM OTOMATİK ÇİFT KAFA DESTEK SACI VİDALAMA MAKİNESİ



						
			Bar	Air Cons.		
1 kW 220V AC 1P 50 Hz,	D: Ø5-Ø10 mm d: Ø3,9-Ø4,2 mm L: 13/16/19/22 mm	Hmin:30mm Hmax:160mm Wmin:20mm Wmax:165 mm	6-8	110 L/min.	150x522x190	415 475

GENERAL FEATURES

- Pneumatic and automatic screw feeding
- Automatic stop after screwing process finishes
- Selection of screw distance in the desired intervals from the screen
- Automatic screw distance measurement with sensor
- Ability to screw in 4 different profile widths
- Simultaneous dual screwing ability
- Protective sensors to prevent misuse
- Height adjustment sensor for special screws
- Automatic clamping of profile during screwing
- Pneumatic range stop for supporting profile
- Automatic screw discharge
- Long-lasting use and easy change of the bit
- Manual screw feeding from the screen
- Exit conveyor for automatic discharge of the product after process ends
- Average screwing speed 1.7 sec /pc.
- Recommended reinforcement sheet thickness 3.0 mm
- Capable of double line screwing
- Mechanical structure suitable for screwing thin profiles

STANDARD ACCESSORIES

- In-feed table on the right and out-feed table on the left

GENEL ÖZELLİKLER

- Havalı otomatik vida besleme ünitesi
- Vidalama işlemi bittikten sonra otomatik olarak durur
- Ekrandan istenilen aralıkta vida mesafesi seçimi
- Sensor ile otomatik vida mesafesi ölçümü
- 4 farklı profil genişliğine göre vida atabilme özelliği
- Aynı anda iki vida atabilme
- Hatalı kullanımı önleyici güvenlik sensörleri
- Özel vidalar için yükseklik ayar sensörü
- Vidalama esnasında profili otomatik sıkıştırma
- Destekli profil dayama mesafesi
- Otomatik vida boşaltma
- Uzun ömürlü uç kullanımı ve kolay değiştirilebilme imkanı
- Ekrandan manuel vida besleme
- İşlem bitince otomatik ürün boşaltan çıkış konveyörü
- Ortalama vidalama hızı 1,7 sn. / adet
- Önerilen destek sacı kalınlığı: maks. 3.0 mm
- Çift hat vidalama özelliği
- İnce profillerin vidalanmasına uygun mekanik yapı

STANDART AKSESUARLAR





- Sağ tarafta profil besleme ve sol tarafta profil çıkış tablaları

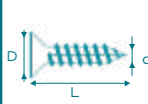
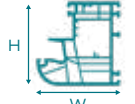

SM 201

SINGLE HEAD REINFORCEMENT STEEL SCREWDRIVER
TEK KAFA DESTEK SACI VIDALAMA MAKİNESİ



					
		Bar	Air Cons.		
D:Ø5-Ø10 mm d:Ø3,9-Ø4,2 mm L:13-16-19-22 mm	Hmin:40mm Hmax:160mm Wmin:40mm Wmax:165 mm	6-8	60 L/min.	62x230x172	100 132

GENERAL FEATURES

- Automatic screw feeding unit
- Foot pedal operation for screwing
- Screwing force and point are adjustable for various kinds of profiles and their models
- Long-lasting use and easy change of the bit
- Automatic stop after finishing screwing
- Safety key to prevent misuse
- Special, adjustment key for the height of screw
- Fixes the material firmly by automatic clamps to prevent movement during screwing
- Adjustable resting distance for the supported type of profiles
- Profile support arms on the left and right sides
- Mechanical sensor on the head guarantees an optimum screwing process
- Screw feed speed approx. 1.7 sec./pc.
- Recommended reinforcement sheet thickness max. 3.0 mm

STANDARD ACCESSORIES

- Profile support arms on the left and right sides

GENEL ÖZELLİKLER

- Otomatik vida besleme ünitesi
- Vidalama için ayak pedallı kontrol
- Değişik model profiller için vidalama kuvveti ve yeri ayarlanabilir
- Uzun ömürlü uç kullanımı ve kolay değiştirme imkanı
- Vidalama işlemi bittikten sonra otomatik durma
- Hatalı kullanımı önleyici güvenlik anahtarı
- Özel vida yükseklik ayarı
- Vidalama esnasında profili otomatik sıkıştırma
- Ayarlanabilir destekli profil dayama mesafesi
- Sağ ve sol tarafta profil destek kolları
- Kafadaki mekanik sensör mekanizması optimum vidalama prosesini garanti eder
- Ortalama vidalama hızı: 1.7 sn. / adet.
- Önerilen destek sacı kalınlığı maksimum 3.0 mm

STANDART AKSESUARLAR

- Sağ ve sol tarafta profil destek kolları

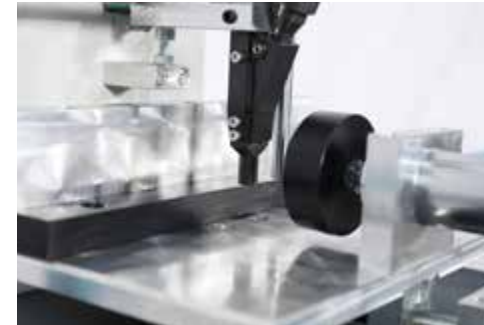

SM 201 SD

DOUBLE HEAD REINFORCEMENT STEEL SCREWDRIVER AND MONTAGE DRILLING MACHINE
ÇİFT KAFA DESTEK SACI VİDALAMA VE PENCERE MONTAJ DELİĞİ DELME MAKİNESİ

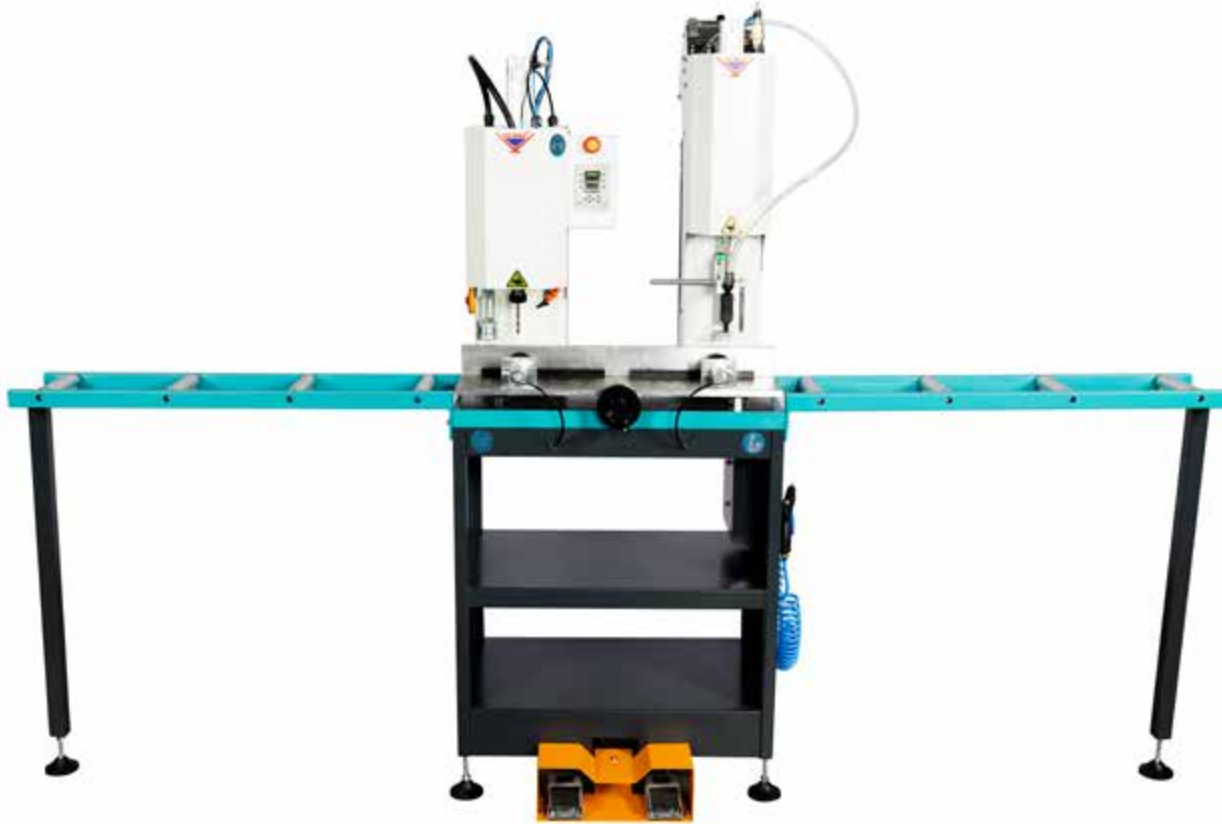

 Dmin: 5 mm Dmax: 10 mm Min. (dxL): Ø3.9x13/16/19/22 Max. (dxL): Ø4.2x13/16/19/22	 Hmin:40mm Hmax:160mm Wmin:40mm Wmax:165 mm			 WxLxH cm	 200 224
		Bar	Air Cons.		
		6-8	10 L/min.		

GENERAL FEATURES

- Ability of reinforcement steel screwing and opening montage drills on the PVC profiles
- Foot pedal operation for both screwing and drilling processes
- Automatic screw feeding unit
- Screwing force and point are adjustable for various kinds of profiles and their models
- Long-lasting use and easy change of the bit
- Automatic stop after finishing screwing
- Safety key to prevent misuse
- Special, adjustment key for the height of screw
- Fixes the material firmly by automatic clamps to prevent movement during screwing
- Adjustable resting distance for the supported type of profiles
- Profile support arms on the left and right sides
- Mechanical sensor on the head guarantees an optimum screwing process
- Screw feed speed approx. 1.7 sec./pc.
- Recommended reinforcement sheet thickness max. 3.0 mm

STANDARD ACCESSORIES

- Profile support arms on the left and right sides

GENEL ÖZELLİKLER

- Destek sacını vidalama ve montaj deliğini açma imkanı
- Vidalama ve delik delme üniteleri için ayrı ayak pedallı kontrol
- Otomatik vida besleme ünitesi
- Değişik model profiller için vidalama kuvveti ve yeri ayarlanabilir
- Uzun ömürlü uç kullanımı ve kolay değiştirme imkanı
- Vidalama ve delik delme işlemi bittikten sonra otomatik durma
- Profile yüksekliğine göre matkap ilerleme mesafesini ayarlayan mekanik hafıza
- Vidalamada hatalı kullanımı önleyici güvenlik anahtarı
- Özel vida yükseklik ayarı
- Vidalama esnasında profili otomatik sıkıştırma
- Ayarlanabilir destekli profil dayama mesafesi
- Sağ ve sol tarafta profil destek kolları
- Kafadaki mekanik sensör mekanizması optimum vidalama prosesini garanti eder
- Ortalama vidalama hızı: 1.7 sn. / adet.
- Önerilen destek sacı kalınlığı maksimum 3.0 mm
- Matkap ölçüsü: Ø8 mm

STANDART AKSESUARLAR

- Sağ ve sol tarafta profil destek kolları

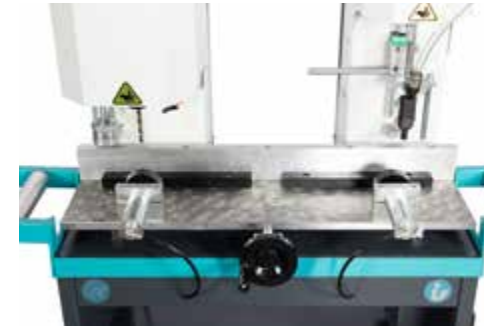

MCA 801

AUTOMATIC MULLION CONNECTOR ASSEMBLY MACHINE
ORTA KAYIT AKSESUAR MONTAJ MAKINASI



380V, 7kW / 7A 3P 50-60 Hz,	D: Ø30 mm 12.000 RPM	Bar 6-8	Air Cons. 60 L/min.	WxLxH cm 95x145x150	200

GENERAL FEATURES

- 2x automatic screw feeding unit
- Foot pedal operation for screwing
- Screwing force and point are adjustable for various kinds of profiles and their models
- Long-lasting use and easy change of the bit
- Automatic stop after finishing screwing
- Safety key to prevent misuse
- Special, adjustment key for the height of screw
- Adjustable mechanical turret for 4 different wedge connectors
- Automatic profile clamping and profile centering system during screwing
- Mechanical sensor on the head guarantees an optimum screwing process
- Screw feed speed approx. 1.7 sec./pc
- Recommended reinforcement sheet thickness max. 2.5 mm

STANDARD ACCESSORIES

- 1x semi-finished connector mold
- 2x apex screw bits
- Hexagon-head bolts in different sizes for mechanical turret

OPTIONAL ACCESSORIES

- Special mold according to customer connector

GENEL ÖZELLİKLER

- 2x otomatik vida besleme ünitesi
- Vidalama için ayak pedallı kontrol
- Değişik model profiller için vidalama kuvveti ve yeri ayarlanabilir
- Uzun ömürlü uç kullanımı ve kolay değiştirme imkanı
- Vidalama işlemi bittikten sonra otomatik durma
- Hatalı kullanımı önleyici güvenlik anahtarı
- Özel vida yükseklik ayarı
- 4 farklı takoza göre ayarlanabilir mekanik rovelver
- Vidalama esnasında profili otomatik baskı ve profil merkezleme sistemi
- Kafadaki mekanik sensör mekanizması optimum vidalama prosesini garanti eder
- Ortalama vidalama hızı: 1.7 sn. / adet
- Önerilen destek sacı kalınlığı maksimum 2.5 mm

STANDART AKSESUARLAR

- 1x yarı işlenmiş takoz kalıbı
- 2x apex vidalama ucu
- Mekanik rovelver için farklı boyutlarda 6 köşe başlı civatalar

OPSİYONEL AKSESUARLAR

- Müşteri konnektörüne göre özel kalıp



A technical drawing of a support structure, likely a crane or lifting mechanism, rendered in white lines on a teal background. The drawing shows a complex assembly of beams, bolts, and a central vertical support. A warning symbol is visible on the left side of the structure. The text is overlaid on the drawing.

SUPPORT EQUIPMENT
DESTEK EKİPMANLARI



BRAKING

CLAMPING

UP-DOWN

VCE 1570

VACUUM CHIP EXTRACTOR VAKUM TALAŞ EMİCİ



GENERAL FEATURES

- High working performance with heavy duty cycle
- Structure completely made in steel and painted with powder coating
- Robust and ergonomic handle
- Centrifugal fan system
- It is also used to clean the metal chips inside the machines and at working environment
- VCE 1570 is ideal for double head mitre saw cutting machines
- Quick release chips container
- Easily transported to the chip storage area thanks to the wheeled chip collection
- Thanks to the air filter cleaning system, there is no need to disassemble the filter unit

STANDARD ACCESSORIES

- Pneumatic filter cleaner with base
- 1pc.xØ100/Ø50 adaptor (VCE 1360)
- 2x Ø160 / Ø100 adaptor and 2x 5m Ø100 hose & clamps (VCE 1570)

GENEL ÖZELLİKLER

- Sürekli çalışma koşullarında yüksek performanslı bir üründür
- Çelik sac malzemeden üretilmiştir ve toz boya ile boyalı gövde
- Sağlam ve ergonomik tutma kolu
- Santrifüj fan sistemi
- Makinelerin içinde ve çalışma ortamındaki metal talaşlarını temizlenmesi amacıyla da kullanılabilir
- Çift kafa kesmeler için VCE 1570 model idealdir
- Kolay ve çabuk ayrılabilir talaş toplama ünitesi
- Tekerlekli talaş toplama ünitesi sayesinde talaş depolama alanına kolaylıkla taşınır
- Havalı filtre temizleme sistemi sayesinde filtrenin sökülmesine gerek kalmaz

STANDART AKSESUARLAR

- Pnömatik filtre temizleyici
- 1ad.xØ100/Ø50 adaptör (VCE 1360)
- 2x Ø160 / Ø100 adaptör ve 2x 5m Ø100 hortum ve & kelepçeler (VCE 1570)

Power (kW) Güç	Voltage & Frequency Voltaj & Frekans	Max. air flow (m3/h) Debi	Max. negative pressure (mbar) Maks. negative basınç	Suction inlet (mm) Emiş çapı	Container capacity Talaş kapasitesi	Noise level (db) Ses seviyesi	Dimensions (mm) Ölçüler	Net weight (kg) Net ağırlık	Filter cleaning Filtre temizleme
2.2	230/400V AC 50-60 Hz,	1.400	30	2x Ø100	100	76	203x84x91	125	pneumatic

GAS 301

WINDOW GLASS ASSEMBLY BENCH PENCERE CAMI MONTAJ MASASI



GENERAL FEATURES

- It is designed for the fast installation of glass on the windows and doors
- Glazed joinery transferring to package on rollers
- Parallel block clamps allow you to set an appropriate balance
- Raising the workpiece 500 mm up for easier installation
- Max. / Min. Frame Mounting Dimensions: 2.700 / 300 mm
- The angle of upper surface of the table is at 70° in order to carry out the mounting of the glasses easy
- Width (W) x Length (L) x Height (H): 900 x 3.050 x 2.400 mm
- Loading capacity: 350 kg

GENEL ÖZELLİKLER

- Kapı ve pencerelere seri şekilde cam takma
- Camı takılmış doğramayı ambalajlamaya makaralar üzerinde aktarma
- Paralel baskı ünitesi ile uygun değerde denge sağlama
- Doğramanın 500 mm yukarı kaldırılması ile montaj kolaylığı
- Maks./Min. çerçeve bağlama genişliği 2.700 / 300 mm
- Cam montajının kolay yapılabilmesi için masa üst yüzeyi 70° eğimlidir
- En (W) x Boy (L) x Yükseklik (H): 900 x 3.050 x 2.400 mm.
- Taşıma kapasitesi 350 kg

HDL 400 - 700

SERVO CONTROLLED AUTOMATIC LENGTH STOPS
SERVO KONTROLLÜ OTOMATİK PROFİL DAYAMA SİSTEMİ



Model	Servo Motor	Maksimum İtme Stroğu (mm)	Minimum Kesme Uzunluğu (mm)	Kullanılabilir Konveyör Genişliği (mm)	Taşıma Kapasitesi (kg/m)	Ölçü Hassasiyeti (mm)	Konveyör Boyutları (cm)	Konveyör Ağırlığı (kg)
Model	Servo Motor	Max. Pushing Stroke (mm)	Min. Cutting Length (mm)	Usable Conveyor Width (mm)	Loading Capacity (kg/m)	Measurement Accuracy (mm)	Conveyor Dimensions (cm)	Conveyor Weight (kg)
HDL 400	1,6 kW 230V AC 50-60 Hz,	3.600	5	300	30	+/- 0.2	85x415x70	190/252
HDL 700	1,6 kW 230V AC 50-60 Hz,	6.600	5	300	30	+/- 0.2	82x424x78	301/372

GENERAL FEATURES

- User menu in Turkish, English, Russian, Spanish and French
- Metric and imperial
- Store up to 50 different lengths
- Manual or automatic operation features
- Easy cutting lists transfer in CSV format with SD card
- 7" HMI colored touch screen monitor
- Preparing cutting lists manually
- Making changes on the cutting lists by the screen
- Technical support with remote access connection via laptop
- Thank to the demount structure, it needs the min. stocking area
- Rack and pinion drive mechanism and rigid steel of construction body provide a repeatable cutting accuracy of +/- 0.008" (0.2 mm) providing superior pushing force for heaviest jobs
- Adapts to handsaw, double or single miter saws, drills, ironworkers, chop saws and more
- Pieces are cut in the order according to the measurement data that is sent from the digital measuring rod (1.5 m - 3.0 m) (optional)

OPTIONAL ACCESSORIES

- Barcode printer
- Digital measuring rod 1.5 m
- Digital measuring rod 3.0 m

GENEL ÖZELLİKLER

- Türkçe, İngilizce, Rusça, İspanyolca ve Fransızca dillerde kullanım menüsü
- Metrik ve İnç olarak kullanma özelliği
- 50 farklı kesim ölçüsü oluşturabilme
- Manuel ve otomatik çalışma özelliği
- SD kart veya Ethernet bağlantısı ile FTP server üzerinden CSV formatında kesim listeleri transferi
- 7" HMI dokunmatik renkli panel ekran
- Manuel reçete oluşturma
- Ekran üzerinden kesim listesinde değişiklik yapabilme özelliği
- Harici laptop ile uzaktan bağlanma ve problem çözme
- Demonte özelliği ile stok alanında tasarruf sağlar
- Kremayer & pinyon dişli ve çelik konstrüksiyon yapısı sayesinde ağır malzemelere yüksek hassasiyet ile +/- 0.008" (0.2 mm) pozisyonlama sağlar
- El testereleri, tek veya iki kafa gönye testereler, matkaplar, demir işleri, doğrama testereleri ve daha pek çok makineye kolaylıkla adapte olur
- Parçalar, ölçü alma çubuğundan gönderilen verilere göre sıraya alınır ve kesim işlemi yapılır (1,5 m - 3.0 m) (opsiyonel)

OPSİYONEL AKSESUARLAR

- Barkod printer
- Dijital Ölçü alma aparatı 1.5 m
- Dijital Ölçü alma aparatı 3.0 m

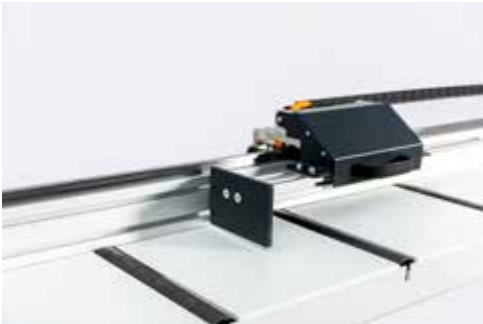

DKN 302 - 602

ROLLER CONVEYOR WITH MANUAL LENGTH STOP & DISPLAY UNIT
DİJİTAL ÖLÇÜ OKUYUCULU MANUEL KONVEYÖR



GENERAL FEATURES

- Manually adjusting to required measurement and positioning by means of the pneumatic brake system
- Digital display indicating the length of the profiles to be cut
- Easy assembly on sawing and copy router machine without conveyor
- Precise and easy positioning of the stop thanks to the hand wheel
- Possibility of working with tree different offset

GENEL ÖZELLİKLER

- Manuel olarak istenilen ölçülere getirilerek pnömomatik fren sistemi ile pozisyonlama sağlanır
- Kesilecek malzemenin uzunluğunu görmek için dijital ölçü okuyucusu mevcuttur
- Kesim ve frezeleme makineleri ile birlikte kullanım özelliği
- Volant kolu ile kolay ve hassas pozisyonlama
- 3 farklı ofset ile çalışabilme imkanı

Model	Maksimum Kesme Uzunluğu (mm)	Minimum Kesme Uzunluğu (mm)	Kullanılabilir Konveyör Genişliği (mm)	Taşıma Kapasitesi (kg/m)	Ölçü Hassasiyeti (mm)	Konveyör Boyutları (cm)	Konveyör Ağırlığı (kg)
Model	Max. Usable Stroke (mm)	Min. Cutting Length (mm)	Usable Conveyor Width (mm)	Loading Capacity (kg/m)	Measurement Accuracy (mm)	Conveyor Dimensions (cm)	Conveyor Weight (kg)
DKN 302	3.000	5	300	30	+/- 0.2	314x57x34	107/150
DKN 602	6.000	5	300	30	+/- 0.2	615x61x34	197/270

MKN 150 - 300 - 301

ROLLER CONVEYOR WITH MANUAL LENGTH STOP
MANUEL DAYAMALI KONVEYÖR



GENERAL FEATURES

- Manually adjusting of the stop to the required measurement and fixing by means of the mechanical brake system
- Ruler for indicating the length of the profiles to be cut
- Cutting profiles up to 6 meter long
- Easy assembly on sawing and copy router machine without conveyor

GENEL ÖZELLİKLER

- Dayama manuel olarak istenilen ölçülere getirilerek mekanik fren sistemi ile pozisyonlama sağlanır
- Kesilecek malzemenin ölçü uzunluğunu görmek için metre okuyucusu
- Maksimum 6 metreye kadar profil kesme imkanı
- Kesim ve frezeleme makineleri ile birlikte kullanım özelliği

Model	Maksimum İtme Stroğu (mm)	Minimum Kesme Uzunluğu (mm)	Kullanılabilir Konveyör Genişliği (mm)	Taşıma Kapasitesi (kg/m)	Ölçü Hassasiyeti (mm)	Konveyör Boyutları (cm)	Konveyör Ağırlığı (kg)
Model	Max. Usable Stroke (mm)	Min. Cutting Length (mm)	Usable Conveyor Width (mm)	Loading Capacity (kg/m)	Measurement Accuracy (mm)	Conveyor Dimensions (cm)	Conveyor Weight (kg)
MKN 150	1.345	5	200	30	+/- 0.2	27x152x90	13/14
MKN 151	1.345	5	300	30	+/- 0.2	36x152x90	15/17
MKN 300	2.845	5	200	30	+/- 0.2	27x304x90	18/19
MKN 301	2.845	5	300	30	+/- 0.2	36x304x90	21/23
MKN 302	2.845	5	400	30	+/- 0.2	47x304x90	25/27

SKN 300 - 600

DIGITAL ROLLER CONVEYOR WITH AUTOMATIC LENGTH STOP
OTOMATİK DAYAMALI DİJİTAL KONVEYÖR



GENERAL FEATURES

- Manual or automatic operation features
- Windows based PLC controlled 15" touch screen monitor
- Preparing cutting lists manually or via PC
- Remote connection and problem solving feature
- Easy program transfer with USB memory stick
- Making changes on the cutting lists by the screen
- Pieces are cut in the order according to the measurement data that is sent from the digital measuring rod

GENEL ÖZELLİKLER

- Manuel veya otomatik çalışma özelliği
- Windows tabanlı 15" bilgisayar kontrollü dokunmatik panel ekran
- Manuel veya bilgisayar üzerinden reçete oluşturma
- Uzaktan bağlanma ve problem çözme
- USB bellek ile kolay program transfer imkanı
- Ekran üzerinden kesim listesinde değişiklik yapabilmek imkanı
- Parçalar, ölçü alma çubuğundan gönderilen verilere göre sıraya alınır ve kesim işlemi yapılır

STANDARD

- Wireless digital measuring device with 1.5 m of measurement capacity

OPTIONAL

- Barcode printer
- Digital measuring device with 3.0 m of measurement capacity

STANDART

- 1.5 m ölçme kapasiteli kablosuz dijital ölçü alma cihazı

OPSİYONEL

- Barkod yazıcı
- 3.0 m ölçme kapasiteli kablosuz dijital ölçü alma cihazı

Model	Motor	Maksimum İtme Stroğu (mm)	Minimum Kesme Uzunluğu (mm)	Kullanılabilir Konveyör Genişliği (mm)	Taşıma Kapasitesi (kg/m)	Ölçü Hassasiyeti (mm)	Konveyör Boyutları (cm)	Konveyör Ağırlığı (kg)
Model	Motor	Max. usable stroke (mm)	Min. Cutting Length (mm)	Usable Conveyor Width (mm)	Loading Capacity (kg/m)	Measurement Accuracy (mm)	Conveyor Dimensions (cm)	Conveyor Weight (kg)
SKN 300	250 W 230V AC 1P 50-60 Hz	2.705	5	250	30	+/- 0.2	58x315x56	130/193
SKN 600	250 W 230V AC 1P 50-60 Hz	5.705	5	250	30	+/- 0.2	58x612x56	214/326

SKN 301

DIGITAL ROLLER CONVEYOR WITH AUTOMATIC LENGTH STOP OTOMATİK DAYAMALI DİJİTAL KONVEYÖR



GENERAL FEATURES

- Self-positioning of the conveyor stop according to the values entered on the digital screen
- It is ideal for cutting glazing bead profiles precisely
- 5.5" touch screen control panel
- Preparation of cutting lists on the control panel
- Possibility of manual or automatic operation
- Easy assembly on sawing and copy router machine without conveyor
- Obtain measurement data from wireless measuring apparatus
- Pieces are cut in the order according to the measurement data from the wireless measuring apparatus
- Digital measuring apparatus with 1.5m of measurement capacity is standard

GENEL ÖZELLİKLER

- Dokunmatik dijital ekranda girilen ölçülere konveyör üzerindeki dayama otomatik olarak gider
- Cam çıtalarını kesme amaçlı olarak kullanılır
- 5.5" dokunmatik kontrol paneli
- Panel üzerinden reçete oluşturma
- Manual veya otomatik çalışma özelliği
- Kesim ve frezeleme makineleri ile birlikte kullanım özelliği
- Kablosuz ölçü alma aparatı üzerinden kesim ölçülerini alma
- Parçalar, ölçü alma aparatından gönderilen verilere göre sıraya alınır ve kesim işlemi yapılır
- 1.5m ölçme kapasiteli kablosuz ölçü alma aparatı standart verilir

STANDARD ACCESSORIES

- Digital measuring device with 1.5 m of measurement capacity

OPTIONAL ACCESSORIES

- Barcode printer
- Digital measuring device with 3.0 m of measurement capacity

STANDART AKSESUARLAR

- 1.5 m ölçme kapasiteli kablosuz ölçü alma aparatı

OPTIONAL ACCESSORIES

- Barcode printer
- Digital measuring device with 3.0 m of measurement capacity

Model	Konveyör Motoru	Maksimum İtme Stroğu (mm)	Minimum Kesme Uzunluğu (mm)	Kullanılabilir Konveyör Genişliği (mm)	Taşıma Kapasitesi (kg/m)	Ölçü Hassasiyeti (mm)	Konveyör Boyutları (cm)	Konveyör Ağırlığı (kg)
Model	Conveyor Motor	Max. Usable Stroke (mm)	Min. Cutting Length (mm)	Usable Conveyor Width (mm)	Loading Capacity (kg/m)	Measurement Accuracy (mm)	Conveyor Dimensions (cm)	Conveyor Weight (kg)
SKN 301	250W 230V AC 1P 50 - 60 Hz	2.705	5	200	30	+/- 0.2	58x315x56	97/157

NSM 352 - 353

PVC SASH ASSEMBLY STATION
PVC KANAT TOPLAMA MERKEZİ

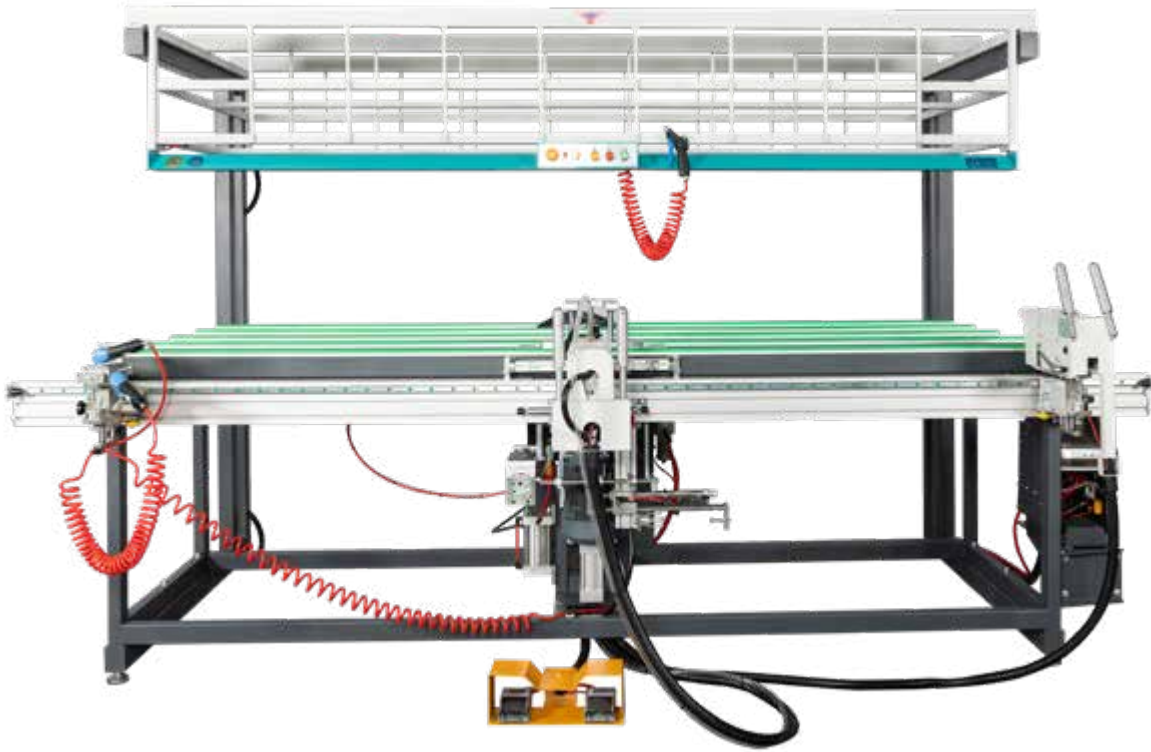

					Bar	Air Cons.		LxHxW cm
NSM 352	0,5 kW 220V AC 1P N PE 50-60 Hz,	Amin: 330 mm Amax: 2.520mm Bmin: 330 mm Bmax: 2.520 mm	Min(dxL): 3,9 x 35 Max(dxL): 4,2 x 38	Amin:30 mm Amax:100mm Bmin:50 mm Bmax:125 mm	6-8	250 L/min.	200x345x200	850
								715
NSM 353	3 kW 380V AC 3P N PE 50-60 Hz,	Amin: 330 mm Amax: 2.520mm Bmin: 330 mm Bmax: 2.520 mm	Min(dxL): 3,9 x 35 Max(dxL): 4,2 x 38	Amin:30 mm Amax:100mm Bmin:50 mm Bmax:125 mm	6-8	250 L/min.	200x345x200	850
								850

NSM 352 and NSM 353 Series of Product Features

NSM 352 ve NSM 353 Serisi Özellikleri

		NSM 352	NSM 353
Sash Assembling Table (Adjustable Template not requiring the Mold change)	Kanat toplama masası (Kalıp değiştirmeden ayarlanabilir şablonlu)	✓	✓
Automatic centring system of window's sash	Pencere kanadını otomatik merkezleme sistemi	✓	✓
Automatic measurement of espagnolettes and scissors	Otomatik ispanyolet ve makas ölçüsü alma sistemi	✓	✓
Punch far espagnolette and scissor stay cutting	İspanyolet ve makas kesim panç	✓	✓
Semi automatic adjustable, Hinge Drilling and Manual Hinge Screwing Group	Yarı otomatik ayarlanabilir, menteşe delme ve manuel menteşe vidalama grubu	✓	✓
Full Automatic Screwing, Automatic screw feeding unit, Laser pointer	Tam otomatik vidalama, otomatik vida besleme ünitesi, lazer vida hizalama sistemi	✓	✓
Hardware shelf (Lighting and Functional Corner Element Hanger)	Aksesuar rafı (Aydınlatma ve fonksiyonel köşe dönüş asma aparatı)	✓	✓
Pim set for Triple hole off-center drilling	Üçlü kol yeri merkezden kaçık delme aparat seti	✗	✓
Milling tool far espagnolette channel grooving for PVC	PVC malzemeye uygun ispanyolet kanal açma frezesi	✗	✓
Triple handle hole drilling group (with reinforced profile)	Üçlü kolyeri delme grubu (destek sacı ile birlikte)	✗	✓

OPTIONAL ACCESSORIES

- Transferring the cutting dimensions of glazing bead profiles to the CK 412U (SKN 301&CK 412) machine set automatically

OPSİYONEL AKSESUARLAR

- CK 412U (SKN 301&CK 412) makine setine cam çitası kesim ölçülerini otomatik olarak gönderme



WB 4000

WORK BENCH MONTAJ MASASI



GENERAL FEATURES

- Working surfaces are covered with rubber material which prevents scratches on work piece and also provides non-sliding
- Opportunity to adjust working area according to profile size in two directions
- Work bench for window assembly and general purposes use
- Adjustable height, fixed on ground and non- slide feet
- Plate to hold the tool set for mount accessories
- Easy mounting air connection coupling
- Standard with 6 pcs. of stacking bin
- Working place length: 2.000 – 4.000 mm
- Working place width: 1.000 – 2.000 mm
- Loading capacity: 350 kg
- Working height: 820 mm

GENEL ÖZELLİKLER

- Çalışma yüzeyi kauçuk malzeme ile kaplı olup, çalışılan profilin çizilmesini engeller
- Yüksekliği ayarlanabilir ve zemine sabitlenebilir, kaymaz plastik ayaklar
- Çalışma alanını profil ebatlarına göre iki yönde ayarlama imkanı
- Pencere montajı ve genel çalışma amaçlı montaj tezgahıdır
- Montaj aksesuarları için avadanlıkların koyulacağı plaka
- Çabuk takılan hava bağlantı kaplini mevcuttur
- 6 adet avadanlık ile beraber verilir
- Çalışma masası genişliği: 2.000 – 4.000 mm
- Çalışma masası derinliği: 1.000 – 2.000 mm
- Taşıma kapasitesi: 350 kg
- Çalışma masası yüksekliği: 820 mm

PWB 4100

PNEUMATIC WORK BENCH PNÖMATİK MONTAJ MASASI



GENERAL FEATURES

- It is designed to be used in the assembly of door, window frame and sash profiles and glasses
- It can expand horizontally and vertically for big frames and sashes
- The upper surface of the table can be tilted to 70° in order to carry out the mounting of the glasses
- There is a pneumatic quick coupling and an electrical outlet on the side of the assembly table for pneumatic and electric tools that can be used in assembly
- Width (W) x Length (L) x Height (H): W: 1.800-3.250 mm x L: 1.700 - 2.200 mm x H: 865 mm
- Maximum Frame Mounting Dimensions 3.200 x 2.800 mm
- Loading capacity: 350 kg

GENEL ÖZELLİKLER

- Kapı, pencere, kasa ve kanat profillerinin ve camlarının montajında kullanılması amacı ile tasarlanmıştır
- Büyük ebatlı kasa ve kanatlar için enine ve boyuna genişleyebilmektedir
- Cam montajının yapılabilmesi için masa üst yüzeyi 70°eğimli hale gelebilmektedir
- Montaj da kullanılacak pnömatik ve elektrikli aletler için montaj masasının yan tarafında pnömatik çabuk bağlantı ve elektrik prizi bulunmaktadır.
- En (W) x Boy(L) x Yükseklik (H): W: 1.800 - 3.250 x L: 1.700 - 2.200 x H: 865 mm.
- Maksimum çerçeve montaj ölçüsü: 3.200 x 2.800 mm
- Taşıma kapasitesi: 350 kg

GPT 1000

GLASS & PROFILE TROLLEY PENCERE TAŞIMA ARABASI



GENERAL FEATURES

- Used for carrying and storing of assembled window sashes and frames
- 4 pcs. of free moving wheel, 2 of which have brakes
- Rolling pulleys making the motion of material carried over ground easy
- Plastic covered surfaces to prevent scratches on work pieces
- 8 sections compatible with minimum and maximum profile size
- Width (W) x Length (L) x Height (H):
W: 990 x L: 1.500 x H: 1.300 mm
- Distance between sections: 140 mm
- Loading capacity: 300 kg

GENEL ÖZELLİKLER

- Bitmiş pencere kasa ve kanatların taşınması ve depolanması amacı ile kullanılır
- 2'si frenli olmak üzere 4 adet tekerlek
- Tabanda taşınan malzemenin hareketini kolaylaştıran döner makaralar
- Yüzeyler malzemenin çizilmesini önlemek amacı ile plastik kaplıdır
- Minimum ve maksimum profil ebatlarına uygun 8 adet bölme mevcuttur
- En (W) x Boy (L) x Yükseklik (H):
W: 990 x L: 1.500 x H: 1.300 mm
- Bölme Arası Mesafe: 140 mm
- Taşıma Kapasitesi: 300 kg



PT 1000

WINDOW TRANSPORTATION TROLLEY PENCERE TAŞIMA ARABASI



GENERAL FEATURES

- Used for carrying and storing completed window assembly
- 4 pcs. of free moving wheel, 2 of which have brakes
- Surfaces are covered with rubber to prevent scratches on work piece
- Width (W) x Length (L) x Height (H):
990 x 1.500 x 1.580 mm
- Loading capacity: 350 kg
- Loading capacity (heavy duty): 500 kg

GENEL ÖZELLİKLER

- Bitmiş pencere kasa ve kanatların taşınması ve depolanması amacı ile kullanılır
- 2'si frenli olmak üzere 4 adet tekerlek mevcuttur
- Yüzeyler malzemenin çizilmesini önlemek amacı ile kauçuk kaplıdır
- En(W) x Boy(L) x Yükseklik(H):
990 x 1.500 x 1.580 mm
- Taşıma kapasitesi: 350 kg
- Taşıma kapasitesi (ağır seri): 500 kg



HP 1000

HORIZONTAL PROFILE TROLLEY YATAY PROFİL TAŞIMA ARABASI



GENERAL FEATURES

- Used for carrying and storing horizontal profiles
- 4 pcs. of free moving wheels, 2 of which have brakes
- Surfaces are covered with rubber to prevent scratches on work piece
- Width (W) x Length (L) x Height (H):
990 x 1.600 x 1.600 mm
- Length of holding bars: 430 mm x 2
- Loading capacity: 350 kg
- Loading capacity (heavy duty): 500 kg

GENEL ÖZELLİKLER

- Yatay profilleri taşımak ve depolamak için kullanılır
- 2'si frenli olmak üzere 4 adet tekerlek mevcuttur
- Yüzeyler malzemenin çizilmesini önlemek amacı ile kauçuk kaplıdır
- En (W) x Boy (L) x Yükseklik (H):
990 x 1.600 x 1.600 mm
- Bölme Çubuklarının Uzunluğu: 430 mm x 2
- Taşıma Kapasitesi: 350 kg
- Taşıma Kapasitesi (ağır seri): 500 kg



VP 1000

VERTICAL PROFILE TROLLEY DİKEY PROFİL TAŞIMA ARABASI



GENERAL FEATURES

- Used for carrying and storing vertical profiles
- 4 pcs. of free moving wheel, 2 of which have brakes
- 2x 10 section is available
- Plastic covered surfaces to prevent scratches on work pieces
- Width (W) x Length (L) x Height (H) :
990 x 1.500 x 1.500 mm
- Distance between sections: 105 mm
- Length of holding bars: 595 mm
- Loading capacity: 500 kg

GENEL ÖZELLİKLER

- Dikey profilleri taşımak ve depolamak için kullanılır
- 2'si frenli olmak üzere 4 adet tekerlek mevcuttur
- 2 x 10 adet bölme mevcuttur
- Yüzeyler malzemenin çizilmesini önlemek için plastik ile kaplıdır
- En (W) x Boy (L) x Yükseklik (H) :
990 x 1.500 x 1.500 mm
- Bölme arası mesafe: 105 mm
- Bölme çubuklarının uzunluğu: 595 mm
- Taşıma kapasitesi: 500 kg



GT 1000

GASKET ROLLER TROLLEY CONTA TAŞIMA ARABASI



GENERAL FEATURES

- Opportunity to mount 4 piece of seal roller
- Adjustable sections according to different seal roller diameters
- Max. roller quantity: 4x Ø550 mm
- Max roller inside diameter: 300 mm
- 4 pcs. of free moving wheels, 2 of which have brakes
- Height: 1.500 mm
- Loading capacity: 300 kg

GENEL ÖZELLİKLER

- 4 adet conta makarası bağlama imkanı
- Farklı makara çaplarına uygun ayarlanabilir bölmeler
- Maksimum bağlanabilir makara sayısı: 4x Ø 550
- Maksimum makara iç çapı: 300 mm
- 2'si frenli olmak üzere 4 adet tekerlek
- Yüksekli: 1.500 mm
- Taşıma kapasitesi :300 kg



RT 1000

ROTATING ASSEMBLY TABLE DÖNEN MONTAJ MASASI



GENERAL FEATURES

- Stable steel construction
- Rotating work table
- Versatile mounting table for window assembly, gasket insertion etc.
- Four pcs of adjustable pull-out arms
- Support arms are rubber coated
- Table surface can be rotated 360° and locked using brake pedal
- With tool rack for pneumatic or electrical tools
- Length of the arms: 700-1.000 mm
- Height: 950 mm
- Loading capacity: 110 kg
- Weight (Brut/Net): 55 – 45 kg

GENEL ÖZELLİKLER

- Sağlam çelik yapı
- Dönebilen çalışma masası
- Pencere montajı, conta takma v.s çok amaçlı montaj tezgahıdır
- Çalışma alanını, profil ebatlarına göre dört yönde ayarlama imkanı
- Destek profilleri kauçuk kaplıdır
- Tabla 360° döner olup kilitlemeli özelliktedir.
- Elektrik veya pnömomatik takım için raf
- Pratik paketleme, montaj ve depolama özelliği
- Kol hareket kapasitesi: 700-1.000 mm
- Yükseklik: 950 mm
- Taşıma kapasitesi: 110 kg
- Ağırlık (Brüt/Net): 55 – 45 kg



PC 4000

PROFILE CARRY CART
PROFİL TAŞIMA ARABASI

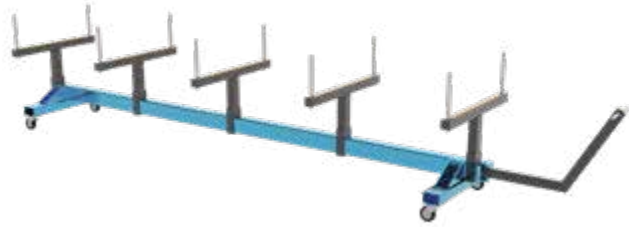

GENERAL FEATURES

- Used for carrying and storing profile of packets
- 4 piece of free moving wheel which have brakes
- Plastic covered surfaces to prevent scratches on work pieces
- Width (W) x Length (L) x Height (H): 855 x 4.000 x 1.000 mm
- Distance between sections: 765 mm
- Length of holding bars: 275 mm
- Loading capacity: 1.000 kg

GENEL ÖZELLİKLER

- Profil paketlerini taşımak ve depolamak için kullanılır
- 4 adet frenli ve dönebilen tekerlek mevcuttur
- Yüzeyler malzemenin çizilmesini önlemek için plastik ile kaplıdır
- En (W) x Boy (L) x Yükseklik (H): 855 x 4.000 x 1.000 mm
- Bölme arası mesafe: 765 mm
- Bölme çubuklarının uzunluğu: 275 mm
- Taşıma kapasitesi: 1.000 kg

PT 2000

WINDOW TROLLEY TWO SIDED
ÇİFT YÖNLÜ PENCERE TAŞIMA ARABASI



GENERAL FEATURES

- Used for carrying and storing completed window assembly
- 4 pcs. of free moving wheel, 2 of which have brakes
- Loading surfaces are covered with rubber to prevent scratches on work piece
- Width (W) x Length (L) x Height (H): 1.740x 1.540 x 1.950 mm
- Loading capacity: 500 kg

GENEL ÖZELLİKLER

- Bitmiş pencere profillerin taşınması ve depolanması amacı ile kullanılır
- 2 si frenli olmak üzere 4 adet tekerlek mevcuttur
- Yüzeyler malzemenin çizilmesini önlemek için kauçuk ile kaplıdır
- En (W) x Boy (L) x Yükseklik (H): 1.740 x 1.540 x 1.950 mm
- Taşıma kapasitesi: 500 kg

VP 2000

WINDIW TROLLEY TWO SIDED ÇİFT YÖNLÜ PENCERE TAŞIMA ARABASI



GENERAL FEATURES

- Used for carrying and storing vertical profiles
- 4 pcs. of free moving wheel, 2 of which have brakes
- 2 x 10 section
- Plastic covered surfaces to prevent scratches on work pieces
- Width (W) x Length (L) x Height (H): 1.440 x 1.540 x 2.000 mm
- Distance between sections: 113 mm
- Length of holding bars: 500 mm
- Loading capacity: 600 kg

GENEL ÖZELLİKLER

- Dikey profilleri taşımak ve depolamak için kullanılır
- 2 'si frenli olmak üzere 4 adet tekerlek mevcuttur
- 2 x 10 adet bölme mevcuttur
- Yüzeyler malzemenin çizilmesini önlemek için plastik ile kaplıdır
- En(W) x Boy(L) x Yükseklik (H): 1.440 x 1.540 x 2.000 mm
- Bölme arası mesafe: 113 mm
- Bölme çubuklarının uzunluğu: 500 mm
- Taşıma kapasitesi: 600 kg



WAS 1000

WINDOW ASSEMBLY STATION PENCERE MONTAJ İSTASYONU



GENERAL FEATURES

- Used to transport frames to assembly stations
- Frames can be slid easily thanks to rollers on the horizontal surface
- There is a roller system to prevent the material from being scratched on the vertical surface.
- The plastic roller width: 200mm
- Width (W) x Length (L) x Height (H): 650 x 3.000 x 1.700 mm
- Carrying and mounting surface: 5.1 m²
- Loading capacity: 200 kg

GENEL ÖZELLİKLER

- Çerçeveleri montaj istasyonlarına taşımak için kullanılır
- Yatay yüzey üzerindeki makaralar sayesinde çerçeveler kolaylıkla kaydırılır
- Dikey yüzeyde malzemenin çizilmesini önlemek için makara sistemi vardır.
- Plastik makara genişliği: 200 mm
- En (W) x Boy (L) x Yükseklik (H): 650 x 3.000 x 1.700 mm
- Taşıma ve montaj yüzey alanı: 5.1 m²
- Taşıma kapasitesi: 200 kg



RS 1000

ROLLER PROFILE SUPPORT MAKARALI PROFİL DESTEK AYAĞI



GENERAL FEATURES

- Stable painted steel construction
- Plastic support rollers
- Adjustable height (900-1,200 mm)
- Support roller diameter: 50 mm
- Support roller length: 500 mm
- Loading capacity: 50 kg
- Weight: 7 kg

GENEL ÖZELLİKLER

- Sağlam boyalı çelik konstrüksiyon
- Plastik destek silindirleri
- Yükseklik ayarlanabilir (900-1.200 mm)
- Destek silindir çapı: 50 mm
- Destek silindiri uzunluğu: 500 mm
- Taşıma Kapasitesi: 50 kg
- Ağırlık: 7 kg

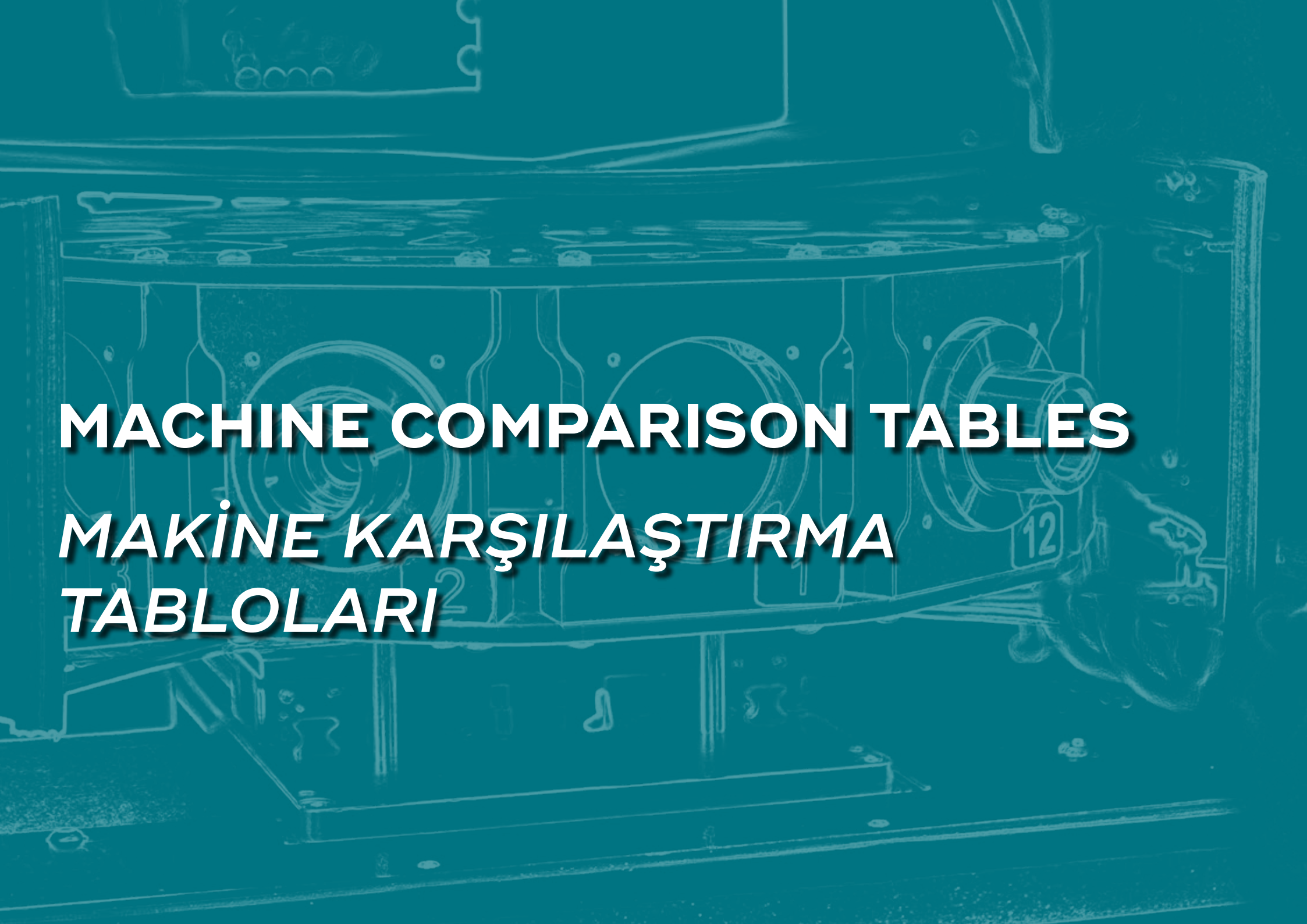

MACHINE COMPARISON TABLES
MAKİNE KARŞILAŞTIRMA
TABLoları

DK & TK SERIES

General Features	Genel Özellikler	DK 540	DK 502	TK 505	TK 503
Number of corner welding	Köşe kaynak sayısı	4	2	1	1
Automatic positioning of welding heads	Kaynak kafalarının otomatik hareketi	✓	manual	-	-
90° of automatic welding function	90° otomatik kaynatma işlemi özelliği	✓	✓	✓	✓
Precision welding capability in the range of 30° - 180°	30 - 180° açı aralığında hassas kaynak yapabilme özelliği	✗	✓	✓	✓
8 " touch screen operator panel	8 " dokunmatik ekranlı operatör paneli	✓	✗	✗	✗
Setting of standard (2 mm) or seamless (0.2 mm) welding options	Standart (2 mm) veya sıfır (0.2 mm) kaynak geçiş özelliği	automatic	manual	manual	manual
Electronic thermostat	Elektronik termostat	✓	✓	✓	✓
Practical welding mould replacement	Pratik kaynak kalıbı değiştirme özelliği	✓	✓	✓	✓
Color and white profile selection mode	Renkli ve beyaz profil seçme modu	✓	✗	✗	✗
Operating system, barcode reader and 900 memory recording features	İşletim sistemi, barkod okuyucu ve 900 adet hafıza kayıt özelliği	✓	✗	✗	✗
Maximum weldable profile size (mm)	Maksimum kaynatılabilir profil ölçüsü (mm)	H:180 W:130	H:180 W:140	H:180 W:130	H:165 W:130
Minimum weldable profile size (mm)	Minimum kaynatılabilir profil ölçüsü (mm)	H:30 W:30	H:30 W:30	H:30 W:30	H:30 W:30
1 set of welding mold according to H:70 mm frame profile	1 set H:70 mm kasa profiline göre kaynak kalıbı	✓	✓	✗	✗
1 set of frame profile adaptor	1 set kanat adaptörü	✓	✗	✗	✗
Custom welding moulds	Özel kaynak kalıpları	optional	optional	optional	optional
CS 240 gasket pressing system	CS 240 conta baskı sistemi	optional	✗	✗	✗
SA 250 cooling unit	SA 250 soğutma ünitesi	optional	✗	✗	✗
SA 251 window buffer station	SA 251 pencere depolama istasyonu	optional	✗	✗	✗

ACK & MK SERIES

General Features	Genel Özellikler	ACK 700	ACK 550	ACK 420 S	MK 420 PS	MK 420	MK 450
Saw blade diameter (mm)	Testere Çapı (mm)	Ø700	Ø550	Ø420	Ø420	Ø420	Ø450
Motor power (kW)	Motor gücü (kW)	4	4	2.2	2.2	2.2	2.2
Cutting with location points at both angle	Sağ ve sol yönde susta ile kesim	✓	✓	✓	✓	✓	✓
Pivoting range from -60° left to +60° right infinitely adjustable	-60° sol ve +60° sağ ara derecelerde hassas kesim	✗	✗	✗	✓	✓	✓
Pivoting range from -75° left to +75° right infinitely adjustable	-75° sol ve +75° sağ ara derecelerde hassas kesim	✓	✓	✓	✗	✗	✗
Two-hand run safety operation	Çift el kumanda uygulaması	✓	✓	✓	✗	✗	✗
Hydro-pneumatic saw feed	Hidro-pnömatik kontrollü testere hareketi	✓	✓	✓	✗	✗	✗
Adjustable saw blade feeding speed	Ayarlanabilir testere çıkış hızı	✓	✓	✓	manual	manual	manual
Safety locking switches on top guard and front door	Üst ve alt kapakta güvenli çalışma kilidi	✓	✓	✓	✓	✗	✗
Spray saw blade lubrication system	Püskürtmeli testere soğutma sistemi	✓	✓	✓	✓	✗	✗
Longitudinal cutting feature	Enine ve boyuna kesme (biçme) özelliği	✗	✗	✗	✓	✓	✓
Roller conveyor (MKN series)	Konveyör (MKN serisi)	MKN 301	MKN 301	MKN 300	optional	optional	optional
Pneumatic clamp kit	Pnömatik mengene kiti	✓	✓	✓	✓	✗	✗
Clamping system	Mengene sistemi	2x Vertical 2x Horizontal	2x Vertical 1x Horizontal	2x Vertical	2x Vertical	manual	manual
Chip extraction system (VCE 1570)	Talaş emme sistemi (VCE 1570)	optional	optional	optional	-	-	-
Roller conveyor (DKN series)	Konveyör (DKN serisi)	optional	optional	optional	-	-	-
Roller conveyor (SKN series)	Konveyör (SKN serisi)	optional	optional	optional	-	-	-
Roller conveyor (HDL series)	Konveyör (HDL serisi)	optional	optional	optional	-	-	-

FR & CRM SERIES

General Features	Genel Özellikler	FR 222	FR 223	FR 223 S	FR 221 S	FR 226 S	CRM 201 S	CRM 250 S
Motor power (kW)	Motor gücü (kW)	1.2	0,75	0,75	0,75/0,55	2 x 0,75	1 x 2,2 2 x 1,1	3 x 1.1
Equipped with Ø5 mm cutter tool for copy router mechanism	Kopya freze tertibatı için takım monteli (Ø5 mm)	✓	✓	✓	✓	✓	✓	✓
Equipped with triple drilling tool set (2x Ø 10, 1x Ø 13mm)	Üçlü kol yeri delme için takım seti monteli (2x Ø 10, 1x Ø 13 mm)	✗	✗	✗	✗	✓ pneumatic	✓	✗
Equipped with tool for water drain mechanism (Ø5 mm)	Su tahliye mekanizması için takım monteli (Ø5 mm)	✗	✗	✗	✗	✗	✓	✗
Maximum, profile machining area (mm)	Maksimum profil işleme alanı (mm)	X:270 Y:120 Z:80	X:270 Y:110 Z:110	X:270 Y:110 Z:110	X:270 Y:110 Z:130	X:270 Y:110 Z:130	X:300 Y:120 Z:130	X1,X2:650,350 Y1,Y2:180,230 Z1,Z2:170,150
Air gun	Hava tabancası	✗	✗	✗	✓	✓	✓	✓
2x profile stop	2x profil dayama	✓	✓	✓	✓	✓	✓	✓
2x horizontal clamp	2x yatay mengene	manual	manual	manual	pneumatic	pneumatic	pneumatic	pneumatic
Spray saw blade cooling system	Püskürtmeli takım soğutma sistemi	✗	✗	✓	✓	✓	✓	✓
MA 240 centring apparatus	MA 240 ortalama aparatı	✗	✗	✗	optional	optional	✗	✗
MKN 150 (1.5 m) roller conveyor	MKN 150 (1.5m) konveyör	✗	optional	optional	optional	optional	✗	✗
Machine stand	Makine sehpası	optional	optional	optional	✓	✓	✓	✓

DC 421 SERIES

General Features	Genel Özellikler	DC 421 PBS	DC 421 PSD
Saw blade diameter (mm)	Testere çapı (mm)	Ø420	Ø420
Tilting automatically to the intermediate angles from 90° to 45° inwards	90°- 45° arasındaki içeri yöndeki derecelere otomatik olarak açığa gitme	pneumatic	pneumatic
Cutting length adjustment	Kesim boyu ölçü ayarı	automatic	automatic
2x profile support	2 x profil desteği	pneumatic	pneumatic
Automatic slicing feature	Otomatik dilimleme özelliği	✓	✓
Technical support with remote access	Uzaktan erişim ile teknik destek imkanı	✓	✗
Cutting list transfer in 'mdb' + 'xls' formats via USB memory and network	USB bellek ve network üzerinden 'mdb' + 'xls' formatında kesim listesi transferi	✓	USB
Windows based industrial PC and 15" touch color panel display	Windows tabanlı endüstriyel PC ve 15" dokunmatik renkli panel ekran	✓	✗
9" touch screen colour display	9" dokunmatik renkli operatör paneli	✗	✓
Barcode printer	Barkod yazıcı	✓	optional
Two-hand safety operation	Çift el çalıştırma güvenliği	✓	✓
Cutting accuracy +/- 0.2 mm	Kesme hassasiyeti +/- 0.2 mm	✓	✓
2 x Ø 420 mm saw blade	2 x Ø 420 mm testere	✓	✓
Spray saw blade cooling system	Püskürtmeli testere soğutma sistemi	✓	✓
4x horizontal clamps	4x yatay mengene	✓	✓
2x vertical clamps	2x dikey mengene	optional	optional
5m & 6m tall custom machine	5m & 6m boyunda özel makine	optional	optional
Short cut system (DKN 71 with ruler)	Küçük parçaları kesmek için dayama sistemi (DKN 71)	optional	optional
Chip extraction system (VCE 1570)	Talaş emme sistemi (VCE 1570)	optional	optional
Arrow cut system for mullion profiles (DKN 80)	Orta kayıt profilleri için ok kesme sistemi (DKN 80)	optional	optional

KD 350 & 400 SERIES

General Features	Genel Özellikler	KD 400 PS	KD 350 PS	KD 400 D	KD 350 D	KD 400 M	KD 350 M
Saw blade diameter (mm)	Testere Çapı (mm)	Ø400	Ø350	Ø400	Ø350	Ø400	Ø350
Equipped with the saw blade	Testere takılı olarak	✓	✓	✓	✓	✓	✓
Location points at 45° - 30° - 22.5° -15° - 0° both left and right	45° - 30° - 22.5 - 15° - 0° açılarda sağ ve sol yönde susta ile kesim	✓	✓	✓	✓	✓	✓
0-45° mitre angle range to the right and left infinitely adjustable	45° sol - 45° sağ ara derecelerde hassas kesim	✓	✓	✓	✓	✓	✓
Machine stand	Makine sehpası	✓	✓	✓	✓	optional	optional
Air gun	Hava tabancası	✓	✓	✗	✗	✗	✗
2x horizontal clamp	2x yatay mengene	pnömatik	pnömatik	manual	manual	manual	manual
MKN 300 (3.0 m) roller conveyor	MKN 300 (3.0 m) konveyör	optional	optional	optional	optional	-	-
Motor braking system	Motor frenleme sistemi	✗	optional	✗	optional	✗	optional
Spray saw blade cooling system	Püskürtmeli testere soğutma sistemi	✓	✓	✗	✗	✗	✗

General Features	Genel Özellikler	KM 212	KM 211 S	KM 215 S
Motor power (W)	Motor gücü (W)	800	1.200/800	1.200/800
Vertical clamp	Dikey mengene	1x manual	1x pneumatic	1x pneumatic
Horizontal clamp	Yatay mengene	1x manual	1x pneumatic	1x pneumatic
Maximum end-milling stroke (mm)	Maksimum profil kertme stroğu (mm)	H:65 W:160	H:90 W:150	H:90 W:225
Maximum profile clamping capacity (mm)	Maksimum profil bağlama kapasitesi (mm)	H:65 W:160	H:160 W:150	H:160 W:225
Multiple end-milling of 1 to 6 pc of sash and frame profiles	1 - 6 adet arası profili çoklu olarak kertme sistemi	×	×	×
Maximum cutter diameter (mm)	Bağlanabilir maksimum bıçak çapı (mm)	Ø 120	Ø 170	Ø 160
Air gun	Hava tabancası	×	✓	✓
Spray saw blade cooling system	Püskürtmeli takım soğutma sistemi	×	✓	✓
Machine stand	Makine sehpası	optional	✓	✓
MKN 100 (1 m) roller conveyor	MKN 100 (1.0 m) konveyör	×	optional	optional
Cutter set	Bıçak seti	optional	optional	optional

WORKSHOP LAYOUTS ATÖLYE PLANLARI

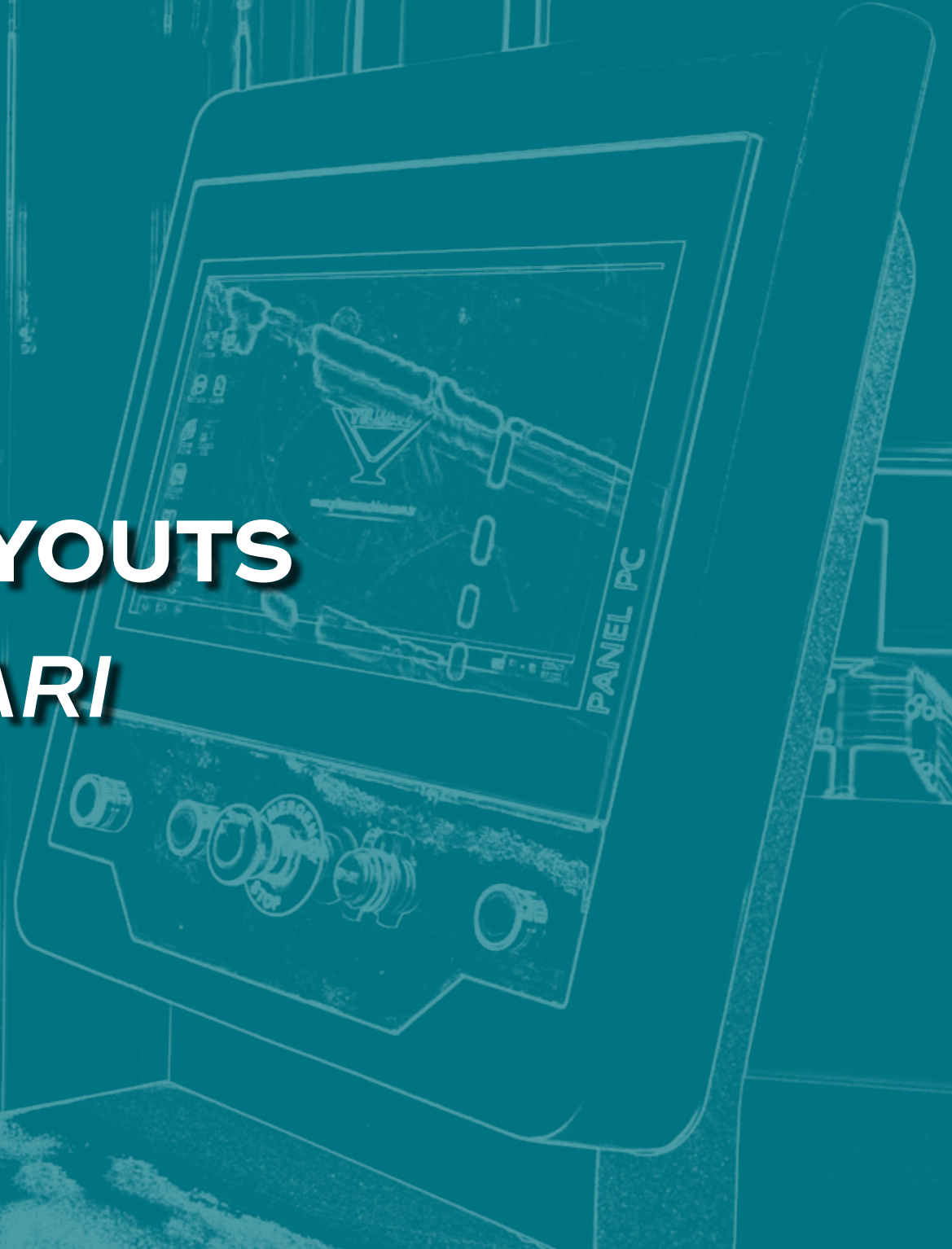

MACHINE SET FOR 45-50 PCS. OF PVC WINDOW FRAMES ON 8 HOURS SHIFT PVC LINE 1

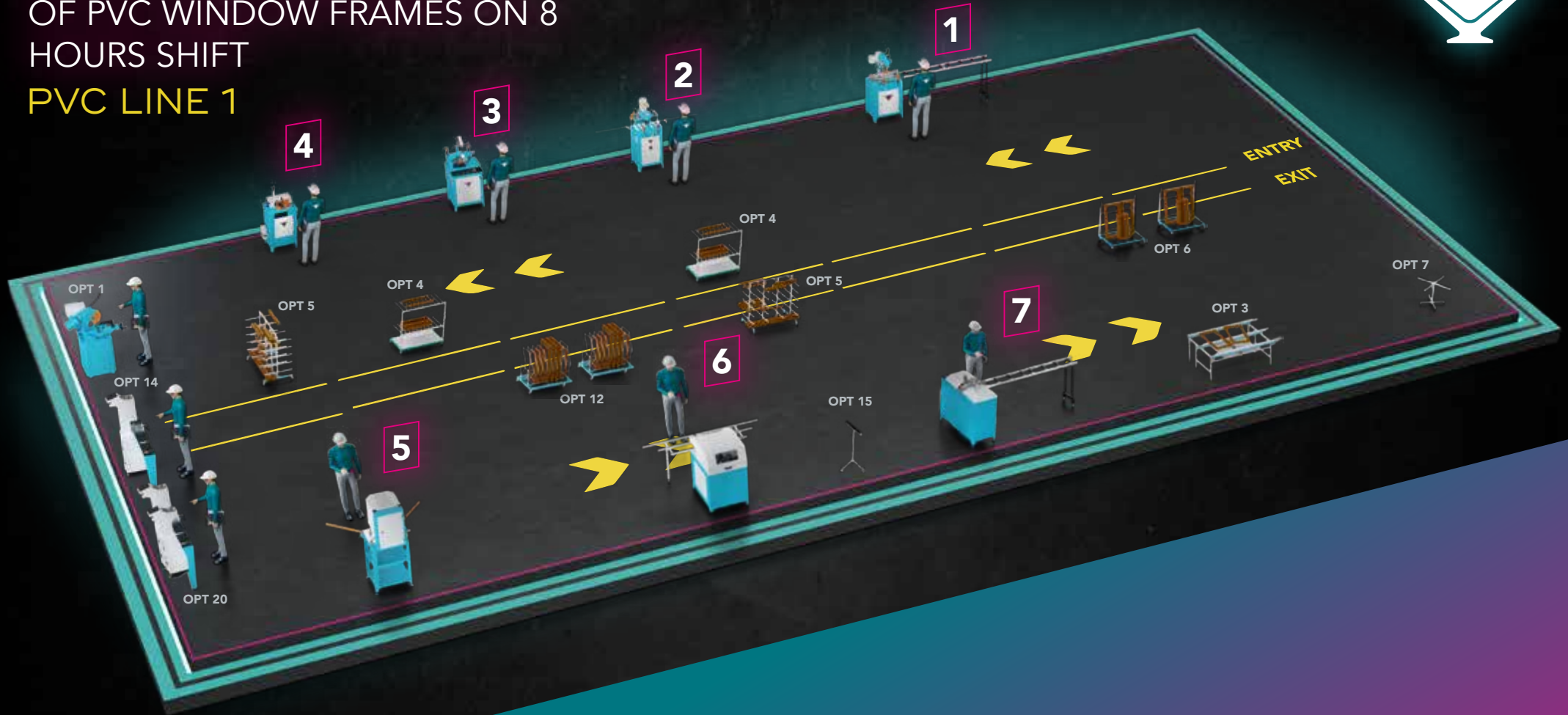

Requirements



Space

25 x 12 m
(300 m²)



Operators

8-10



Compressed Air

6 - 8 bar
500 L/min



Electricity

14 kW

Main Machines

- 1 **KD 400 PS** Miter Saw Machine
- 2 **FR 226 S** Template Copy Router with Triple Hole Drill
- 3 **ST 264** PVC Automatic Water Slot Machine
- 4 **KM 211 S** Manual End-Milling Machine
- 5 **TK 503** Single Corner PVC Welding Machine
- 6 **CA 601** Semi-Automatic PVC Single Corner Cleaning Machine
- 7 **CK 412** PVC Glazing Bead Saw

Optional Machines

- OPT 1 **SDT 275** Reinforcement - Pipe Cutting Saw
-
- OPT 3 **WB 4000** Work Bench
- OPT 4 **VP 1000 (2 pcs)** Vertical Profile Trolley
- OPT 5 **HP 1000 (2 pcs)** Horizontal Profile Trolley
- OPT 6 **PT 1000 (2 pcs)** Product Transportation Trolley
- OPT 7 **RT 1000** Rotating Table
- OPT 12 **GPT 1000 (2 pcs)** Glass & Window Trolley
-
- OPT 14 **SM 201** Single Head Reinforcement Steel Screwdriver
- OPT 20 **SM 201 SD** Double Head Reinforcement Steel Screwdriver and Montage Drilling
- OPT 15 **RS 1000** Roller Profile Support

MACHINE SET FOR 50-60 PCS.
OF PVC WINDOW FRAMES ON 8
HOURS SHIFT
PVC LINE 2

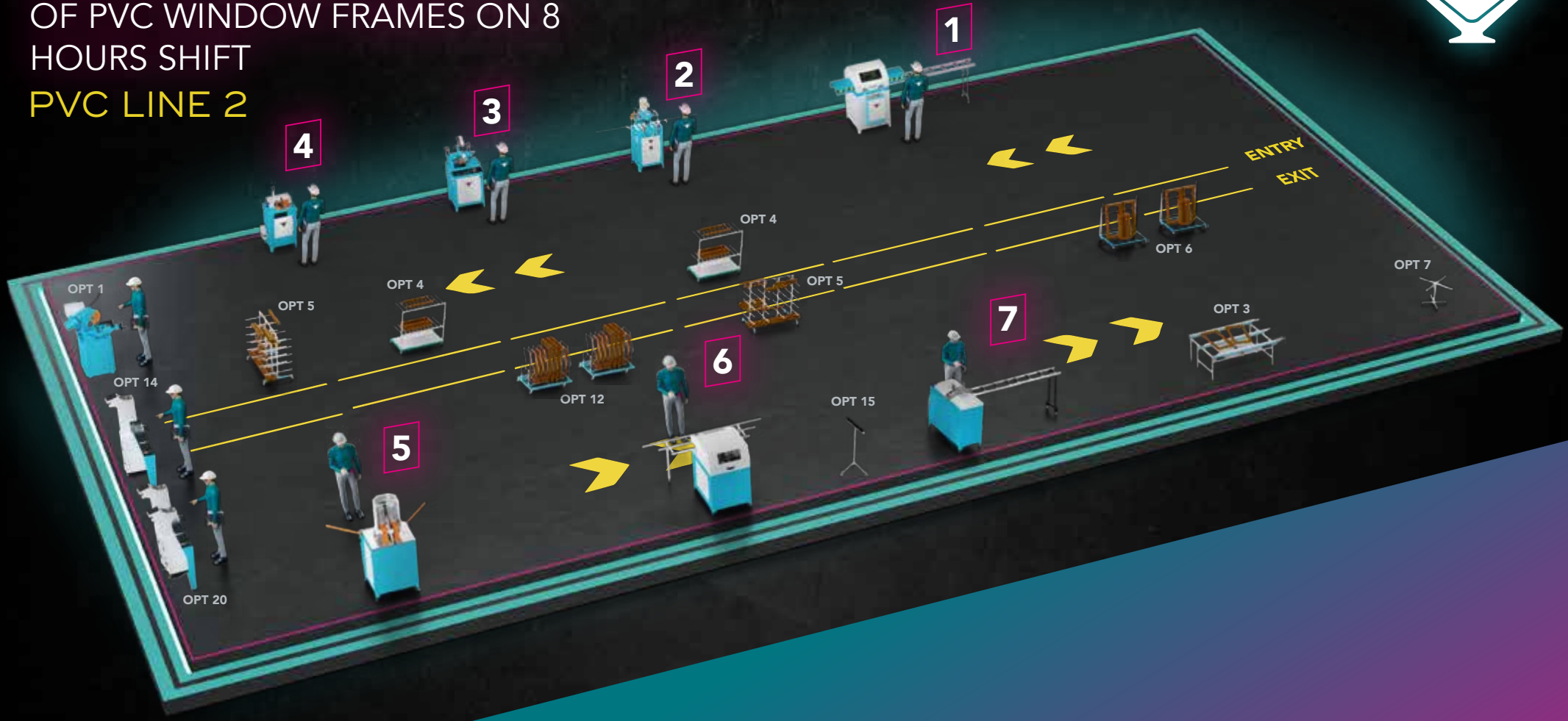

Requirements



Space

25 x 12 m
(300 m²)



Operators

8-10



Compressed Air

6 - 8 bar
500 L/min



Electricity

14 kW

Main Machines

- 1 **ACK 420 S** Up-Cutting Saw Machine
- 2 **FR 226 S** Template Copy Router with Triple Hole Drill
- 3 **ST 264** PVC Automatic Water Slot Machine
- 4 **KM 211 S** Manual End-Milling Machine
- 5 **TK 505** Single Corner PVC Welding Machine
- 6 **CA 601** Semi-Automatic PVC Single Corner Cleaning Machine
- 7 **CK 412** PVC Glazing Bead Saw

Optional Machines

- OPT 1 **SDT 275** Reinforcement - Pipe Cutting Saw
-
- OPT 3 **WB 4000** Work Bench
- OPT 4 **VP 1000 (2 pcs)** Vertical Profile Trolley
- OPT 5 **HP 1000 (2 pcs)** Horizontal Profile Trolley
- OPT 6 **PT 1000 (2 pcs)** Product Transportation Trolley
- OPT 7 **RT 1000** Rotating Table
- OPT 12 **GPT 1000 (2 pcs)** Glass & Window Trolley
-
- OPT 14 **SM 201** Single Head Reinforcement Steel Screwdriver
- OPT 20 **SM 201 SD** Double Head Reinforcement Steel Screwdriver and Montage Drilling
- OPT 15 **RS 1000** Roller Profile Support

MACHINE SET FOR 60-70 PCS.
OF PVC WINDOW FRAMES ON 8
HOURS SHIFT
PVC LINE 3

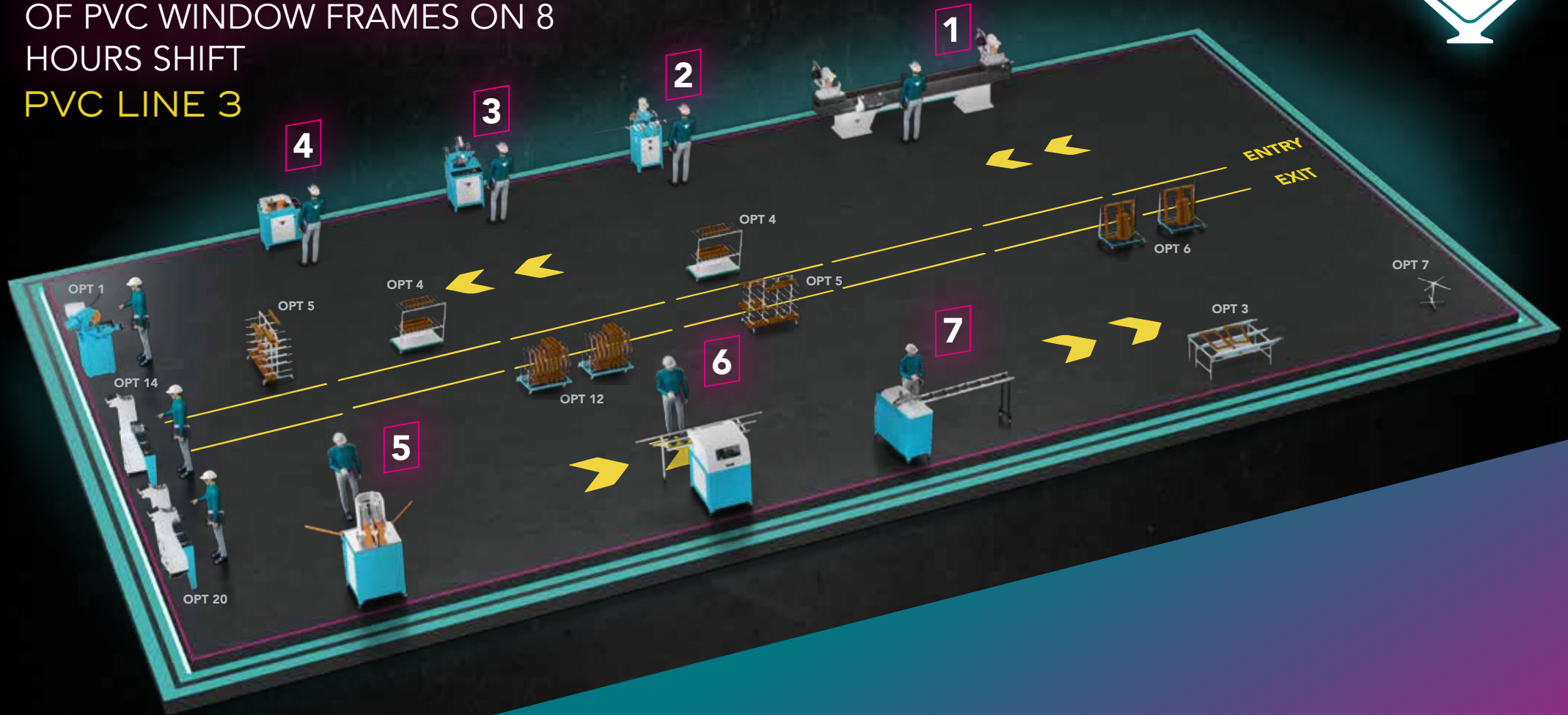

Requirements



Space

25 x 12 m
(300 m²)



Operators

8-10



Compressed Air

6 - 8 bar
500 L/min



Electricity

17 kW

Main Machines

- 1 **KD 402 S** Double Head Mitre Saw Machine
- 2 **FR 226 S** Template Copy Router with Triple Hole Drill
- 3 **ST 264** PVC Automatic Water Slot Machine
- 4 **KM 215 S** Semi-Automatic End-Milling Machine
- 5 **TK 505** Double Corner PVC Welding Machine
- 6 **CA 601** Semi-Automatic PVC Single Corner Cleaning Machine
- 7 **CK 412** PVC Glazing Bead Saw

Optional Machines

- OPT 1 **SDT 275** Reinforcement - Pipe Cutting Saw
- OPT 3 **WB 4000** Work Bench
- OPT 4 **VP 1000 (2 pcs)** Vertical Profile Trolley
- OPT 5 **HP 1000 (2 pcs)** Horizontal Profile Trolley
- OPT 6 **PT 1000 (2 pcs)** Product Transportation Trolley
- OPT 7 **RT 1000** Rotating Table
- OPT 12 **GPT 1000 (2 pcs)** Glass & Window Trolley
- OPT 14 **SM 201** Single Head Reinforcement Steel Screwdriver
- OPT 20 **SM 201 SD** Double Head Reinforcement Steel Screwdriver and Montage Drilling

MACHINE SET FOR 70-80 PCS. OF PVC WINDOW FRAMES ON 8 HOURS SHIFT PVC LINE 4

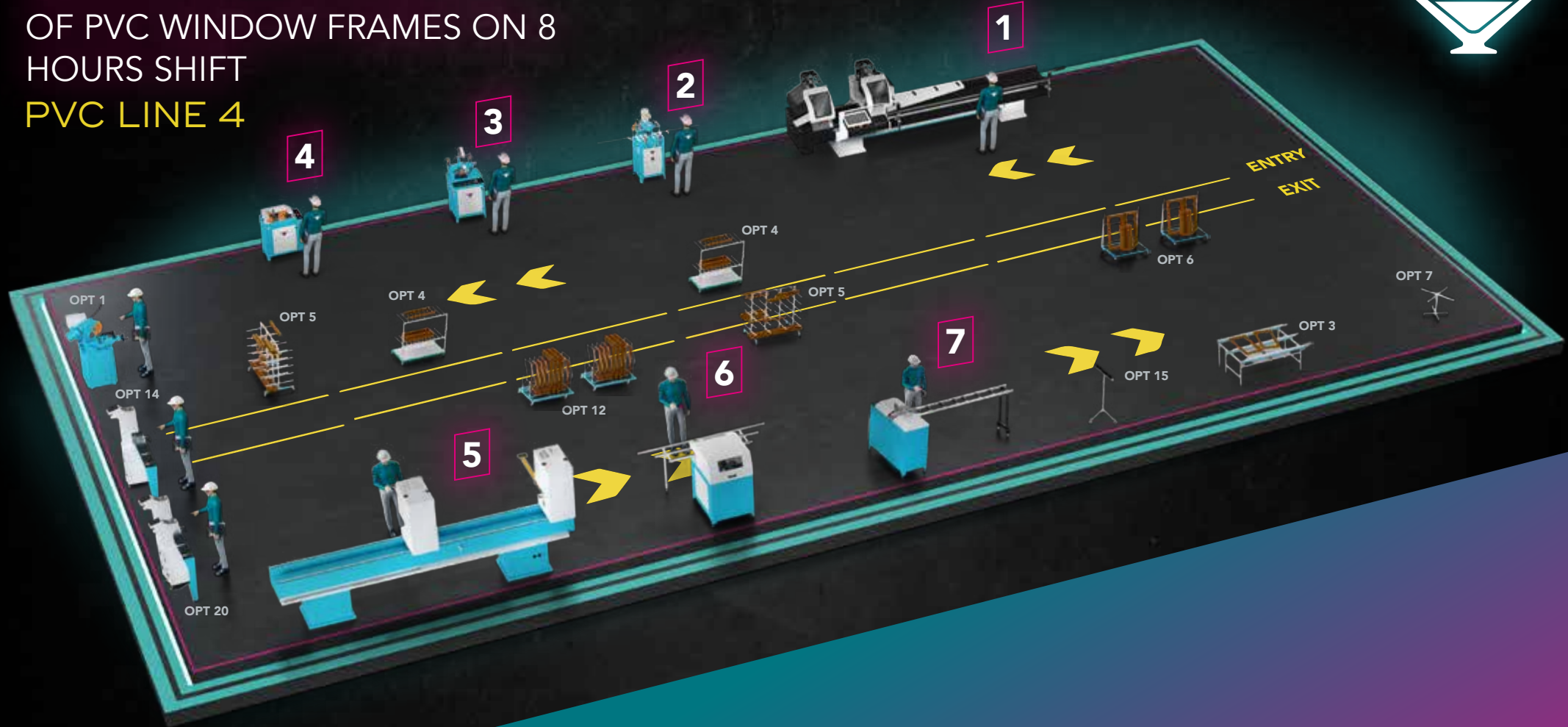

Requirements



Space

25 x 12 m
(300 m²)



Operators

8-10



Compressed Air

6 - 8 bar
500 L/min



Electricity

17 kW

Main Machines

- 1 **DC 421 PSD** Double Head Mitre Saw Machine
- 2 **FR 226 S** Template Copy Router with Triple Hole Drill
- 3 **ST 264** PVC Automatic Water Slot Machine
- 4 **KM 215 S** Semi-Automatic End-Milling Machine
- 5 **DK 502** Double Corner PVC Welding Machine
- 6 **CA 603** PVC Corner Cleaning Machine (4 Cutters)
- 7 **CK 412** PVC Glazing Bead Saw

Optional Machines

- OPT 1 **SDT 275** Reinforcement - Pipe Cutting Saw
-
- OPT 3 **WB 4000** Work Bench
- OPT 4 **VP 1000 (2 pcs)** Vertical Profile Trolley
- OPT 5 **HP 1000 (2 pcs)** Horizontal Profile Trolley
- OPT 6 **PT 1000 (2 pcs)** Product Transportation Trolley
- OPT 7 **RT 1000** Rotating Table
- OPT 12 **GPT 1000 (2 pcs)** Glass & Window Trolley
-
- OPT 14 **SM 201** Single Head Reinforcement Steel Screwdriver
- OPT 20 **SM 201 SD** Double Head Reinforcement Steel Screwdriver and Montage Drilling
- OPT 15 **RS 1000** Roller Profile Support

MACHINE SET FOR 80-90 PCS. OF PVC WINDOW FRAMES ON 8 HOURS SHIFT PVC LINE 5

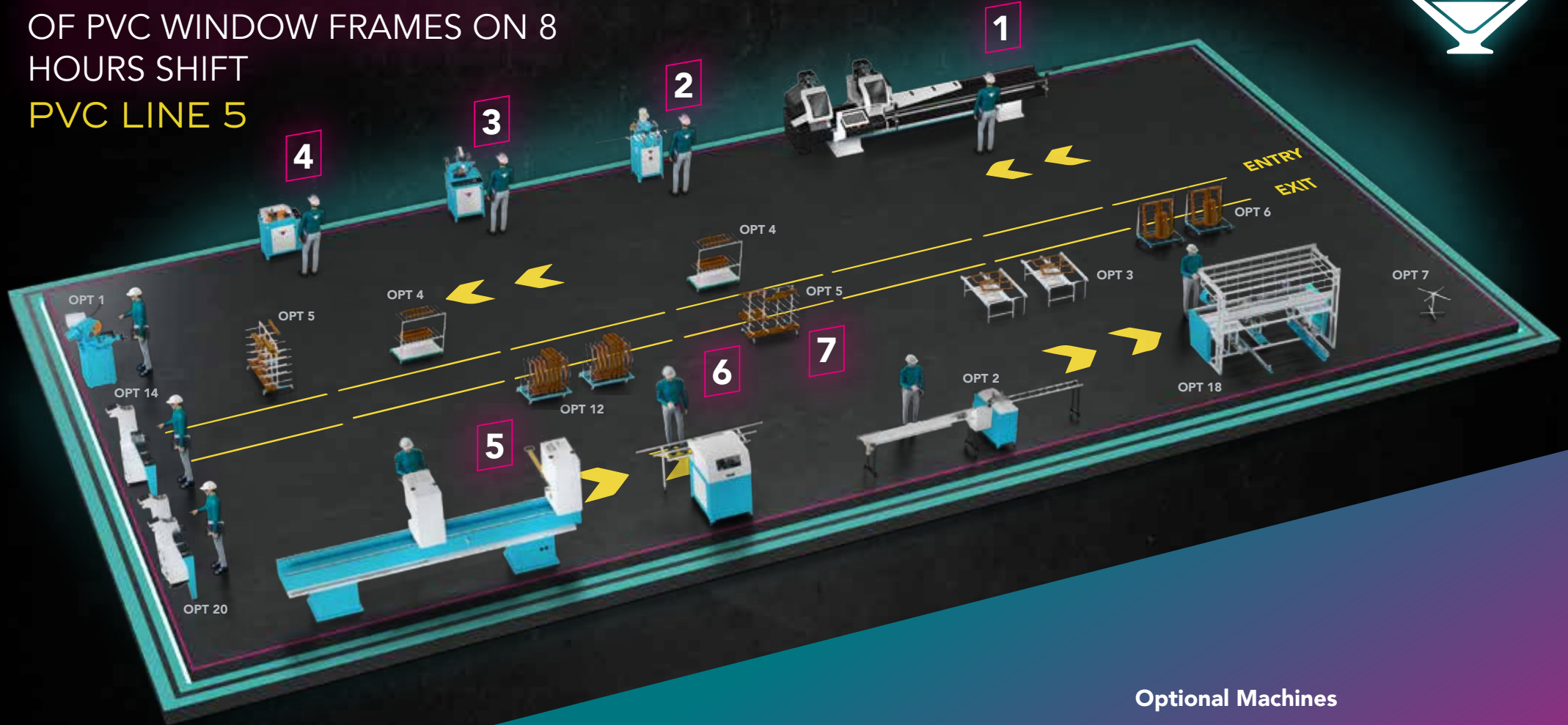

Requirements



Space

25 x 12 m
(300 m²)



Operators

8-10



Compressed Air

6 - 8 bar
500 L/min



Electricity

17 kW

Main Machines

- 1 **DC 421 PSD** Double Head Mitre Saw Machine (Full Automatic)
- 2 **FR 226 S** Template Copy Router with Triple Hole Drill
- 3 **ST 264** PVC Automatic Water Slot Machine
- 4 **KM 215 S** Semi-Automatic End-Milling Machine
- 5 **DK 502** Double Corner PVC Welding Machine
- 6 **CA 603** PVC Corner Cleaning Machine (4-6 Cutters)
- 7 **CK 412** PVC Glazing Bead Saw

Optional Machines

- OPT 1 **SDT 275** Reinforcement - Pipe Cutting Saw
 OPT 2 **SKN 301** Digital Roller Conveyor with Automatic Length Stop
-
- OPT 3 **WB 4000 (2 pcs)** Work Bench
 OPT 4 **VP 1000 (2 pcs)** Vertical Profile Trolley
 OPT 5 **HP 1000 (2 pcs)** Horizontal Profile Trolley
 OPT 6 **PT 1000 (2 pcs)** Product Transportation Trolley
 OPT 7 **RT 1000** Rotating Table
 OPT 12 **GPT 1000 (2 pcs)** Glass & Window Trolley
-
- OPT 14 **SM 201** Single Head Reinforcement Steel Screwdriver
 OPT 20 **SM 201 SD** Double Head Reinforcement Steel Screwdriver and Montage Drilling
-
- OPT 18 **NSM 352** Sash Assembly Station

MACHINE SET FOR 90-100 PCS. OF PVC WINDOW FRAMES ON 8 HOURS SHIFT PVC LINE 6

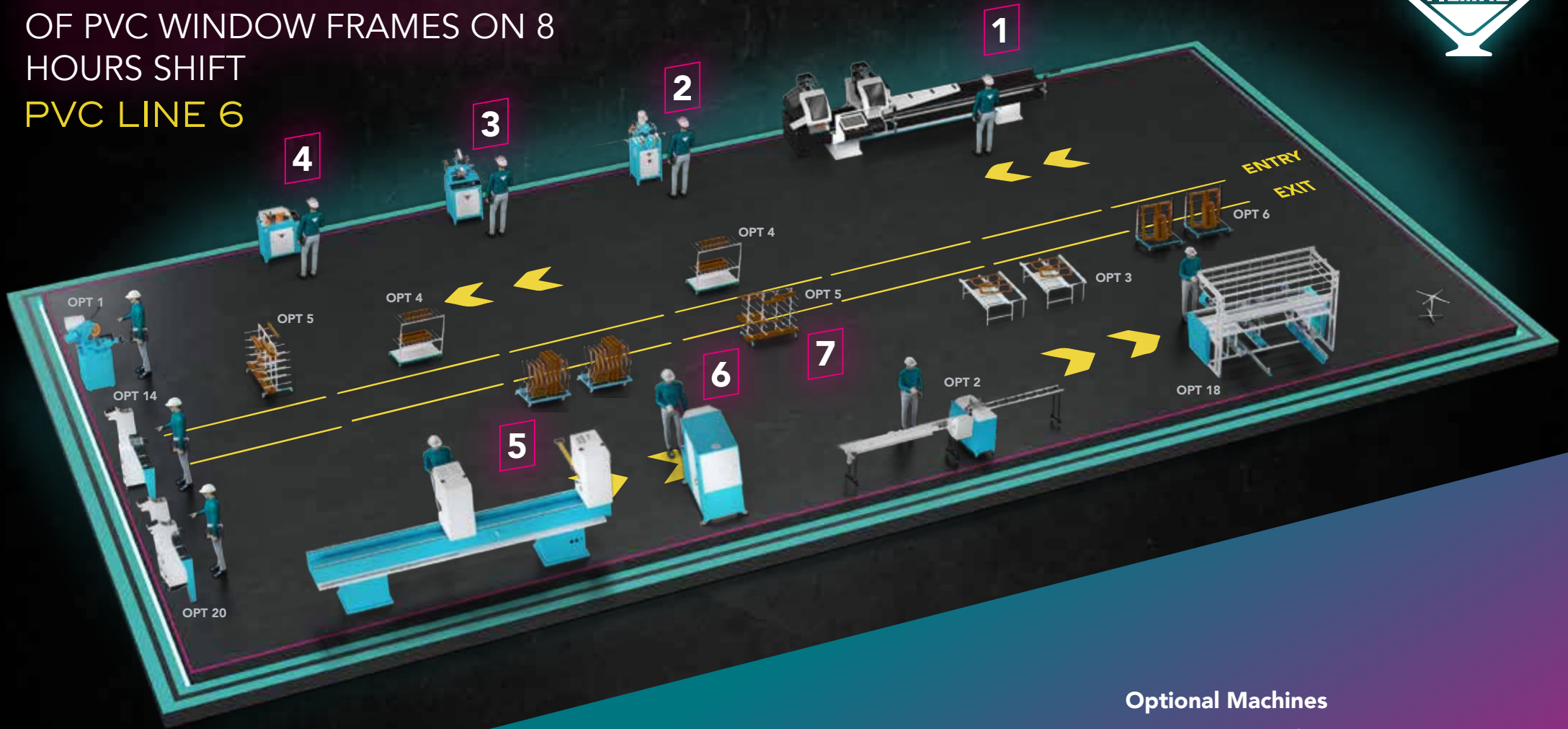

Requirements



Space
25 x 12 m
(300 m²)



Operators
8-10



Compressed Air
6 - 8 bar
500 L/min



Electricity
17 kW

Main Machines

- 1 **DC 421 PBS** Double Head Mitre Saw Machine (Full Automatic)
- 2 **FR 226 S** Automatic Copy Router Machine
- 3 **ST 264** PVC Automatic Water Slot Machine
- 4 **KM 215 S** Semi-Automatic End-Milling Machine
- 5 **DK 502** Double Corner PVC Welding Machine
- 6 **CNC 608** PVC Corner Cleaning Machine (2 axis)
- 7 **CK 412** PVC Glazing Bead Saw

Optional Machines

- OPT 1 **SDT 275** Reinforcement - Pipe Cutting Saw
OPT 2 **SKN 301** Digital Roller Conveyor with Automatic Length Stop
-
- OPT 3 **WB 4000 (2 pcs)** Work Bench
OPT 4 **VP 1000 (2 pcs)** Vertical Profile Trolley
OPT 5 **HP 1000 (2 pcs)** Horizontal Profile Trolley
OPT 6 **PT 1000 (2 pcs)** Product Transportation Trolley
OPT 7 **RT 1000** Rotating Table
OPT 12 **GPT 1000 (2 pcs)** Glass & Window Trolley
-
- OPT 14 **SM 201** Single Head Reinforcement Steel Screwdriver
OPT 20 **SM 201 SD** Double Head Reinforcement Steel Screwdriver and Montage Drilling
-
- OPT 18 **NSM 352** Sash Assembly Station

MACHINE SET FOR 100-120 PCS.
OF PVC WINDOW FRAMES ON 8
HOURS SHIFT
PVC LINE 7

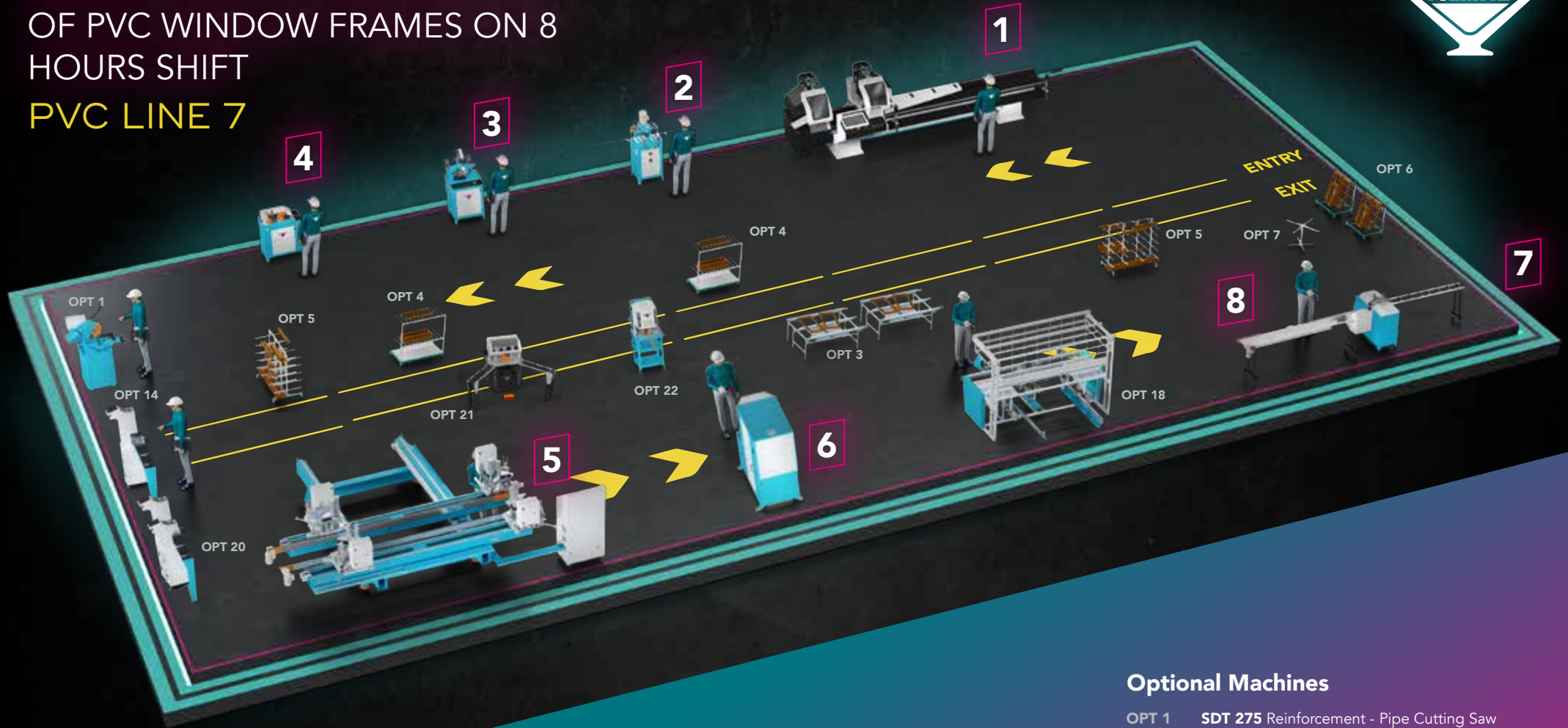

Requirements



Space

25 x 12 m
(300 m²)



Operators

8-10



Compressed Air

6 - 8 bar
500 L/min



Electricity

17 kW

Main Machines

- 1 **DC 421 PBS** Double Head Mitre Saw Machine (Full-Automatic)
- 2 **FR 226 S** Automatic Copy Router Machine
- 3 **ST 264** PVC Automatic Water Slot Machine
- 4 **KM 215 S** Semi-Automatic End-Milling Machine
- 5 **DK 540** Four Corner Cleaning Machine
- 6 **CNC 608** PVC Corner Cleaning Machine (2 axis)
- 7 **CK 412 U** PVC Glazing Bead Saw
- 8 **SKN 301** Digital Roller Conveyor with Automatic Length Stop



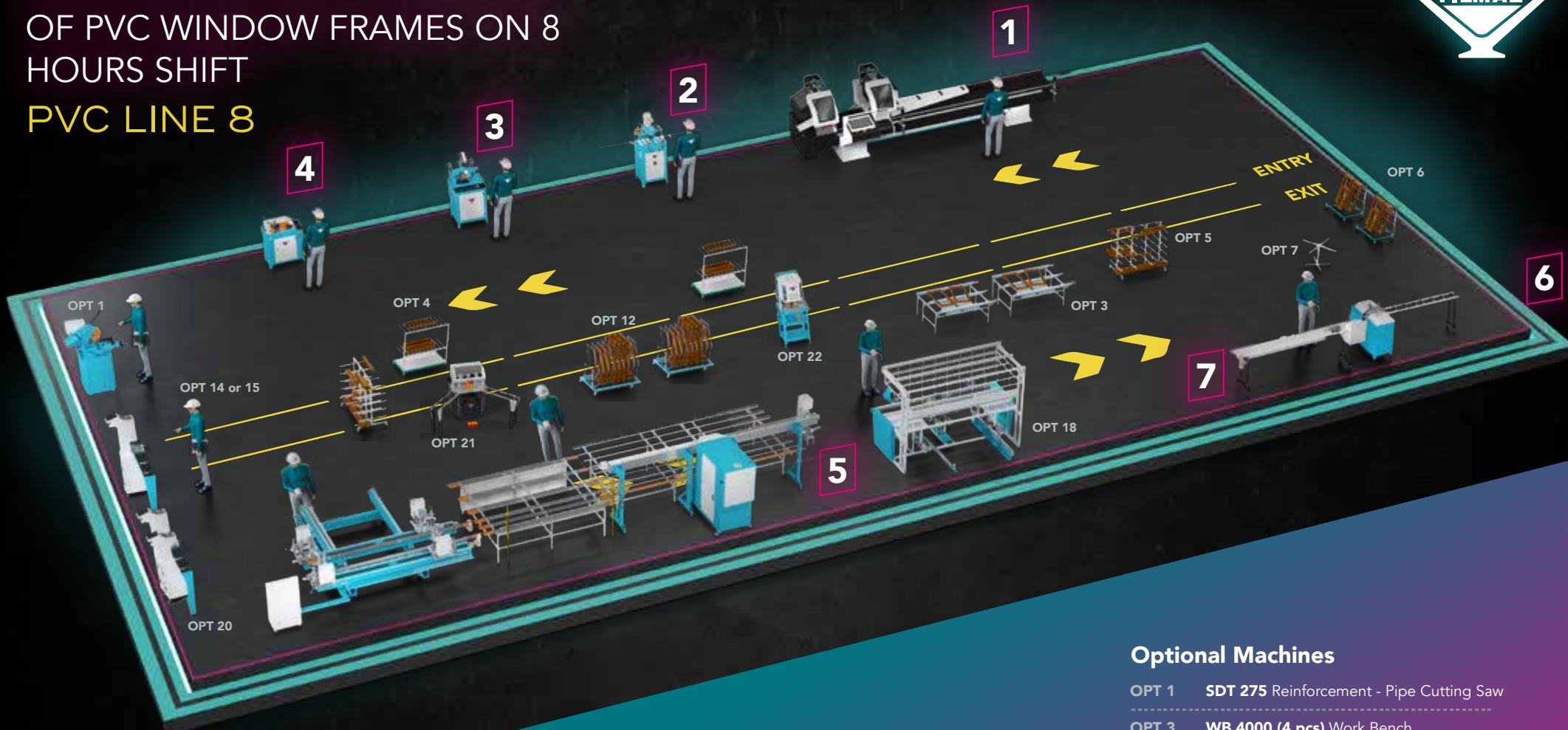

Optional Machines

- OPT 1 **SDT 275** Reinforcement - Pipe Cutting Saw
-
- OPT 3 **WB 4000 (2 pcs)** Work Bench
- OPT 4 **VP 1000 (2 pcs)** Vertical Profile Trolley
- OPT 5 **HP 1000 (2 pcs)** Horizontal Profile Trolley
- OPT 6 **PT 1000 (2 pcs)** Product Transportation Trolley
- OPT 7 **RT 1000** Rotating Table
- OPT 12 **GPT 1000 (2 pcs)** Glass & Window Trolley
-
- OPT 14 **SM 201** Single Head Reinforcement Steel Screwdriver
- OPT 20 **SM 201 SD** Double Head Reinforcement Steel Screwdriver and Montage Drilling
-
- OPT 18 **NSM 352** Sash Assembly Station
- OPT 21 **WGM 202** Window Gasket Milling Machine
- OPT 22 **MCA 801** Automatic Mullion Connector Assembly Machine

MACHINE SET FOR 170-200 PCS. OF PVC WINDOW FRAMES ON 8 HOURS SHIFT PVC LINE 8



Requirements

- 
 Space
 30 x 22 m
 (660 m²)
- 
 Operators
 8-10
- 
 Compressed Air
 8 - 10 bar
 660 L/min
- 
 Electricity
 28 kW

Main Machines

- 1 **DC 421 PBS** Double Head Mitre Saw Machine (Full-Automatic)
- 2 **FR 226 S** Automatic Copy Router Machine
- 3 **ST 264** PVC Automatic Water Slot Machine
- 4 **KM 215 S** Semi-Automatic End-Milling Machine
- 5 **CCL 1660** PVC Welding and Corner Cleaning Line (DK 540 CS, CNC 608)
- 6 **CK 412 U** PVC Glazing Bead Saw
- 7 **SKN 301** Digital Roller Conveyor with Automatic Length Stop

Optional Machines

- OPT 1 **SDT 275** Reinforcement - Pipe Cutting Saw
- OPT 3 **WB 4000 (4 pcs)** Work Bench
- OPT 4 **VP 1000 (4 pcs)** Vertical Profile Trolley
- OPT 5 **HP 1000 (4 pcs)** Horizontal Profile Trolley
- OPT 6 **PT 1000 (4 pcs)** Product Transportation Trolley
- OPT 7 **RT 1000 (2 pcs)** Rotating Table
- OPT 12 **GPT 1000 (2 pcs)** Glass & Window Trolley
- OPT 14 **SM 201** Single Head Reinforcement Steel Screwdriver
- OPT 15 **SM 206** Fully Automatic Double Head Reinforcement Steel Screwdriver
- OPT 20 **SM 201 SD** Double Head Reinforcement Steel Screwdriver and Montage Drilling
- OPT 18 **NSM 352** Sash Assembly Station
- OPT 21 **WGM 202** Window Gasket Milling Machine
- OPT 22 **MCA 801** Automatic Mullion Connector Assembly Machine

MACHINE SET FOR 250-280 PCS. OF PVC WINDOW FRAMES ON 8 HOURS SHIFT PVC LINE 9

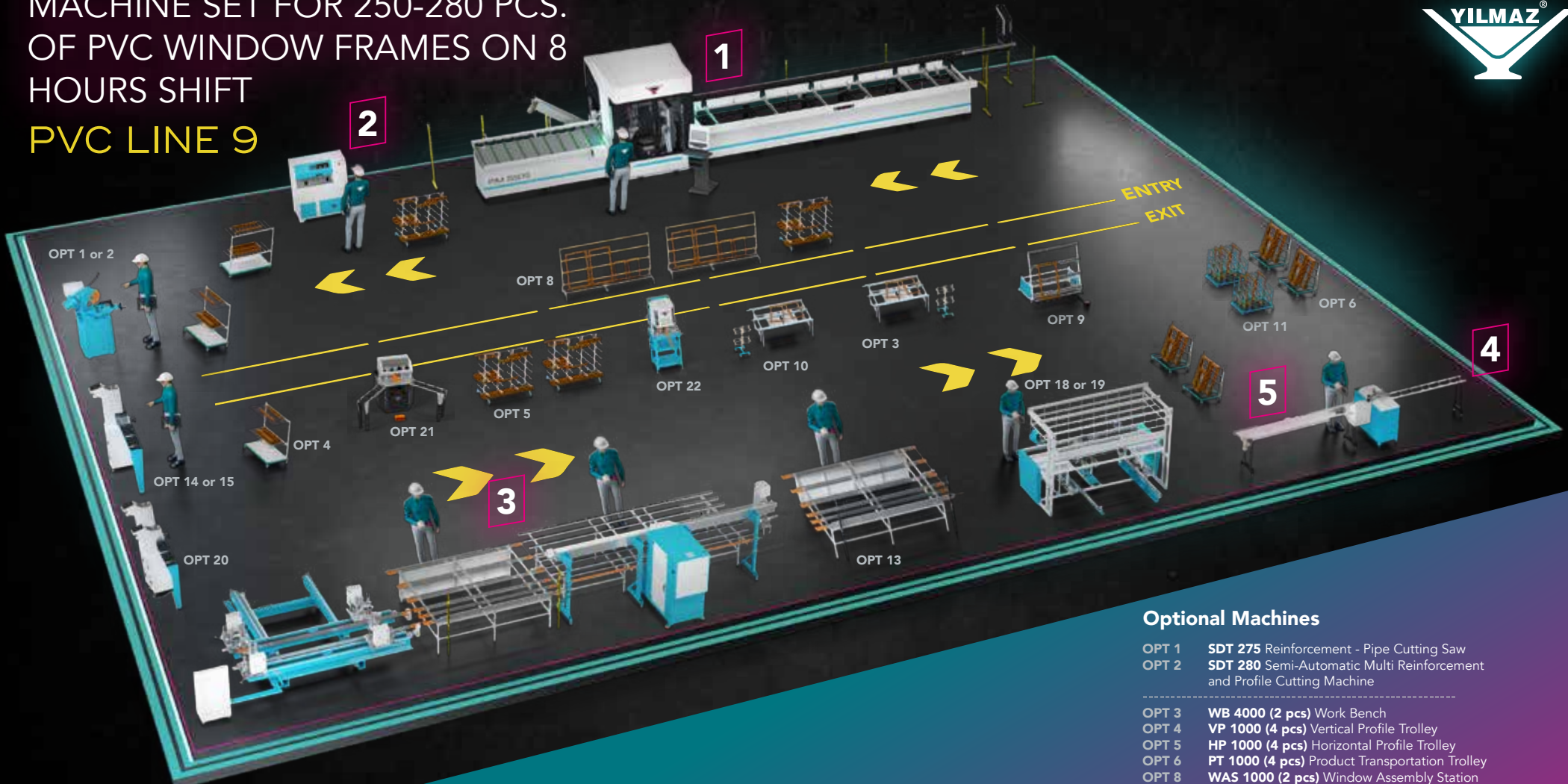

Requirements



Space

25 x 22 m
(550 m²)



Operators

8-10



Compressed Air

8 - 10 bar
660 L/min



Electricity

32 kW

Main Machines

- 1 **PIM 6509** PVC Profile Processing Center
- 2 **KM 215 S** Semi-Automatic End-Milling Machine
- 3 **CCL 1660** PVC Welding and Corner Cleaning Line (DK 540 CS, CNC 610)
- 4 **CK 412 U** PVC Glazing Bead Saw
- 5 **SKN 301** Digital Roller Conveyor with Automatic Length Stop

Optional Machines

- OPT 1 **SDT 275** Reinforcement - Pipe Cutting Saw
 OPT 2 **SDT 280** Semi-Automatic Multi Reinforcement and Profile Cutting Machine
-
- OPT 3 **WB 4000 (2 pcs)** Work Bench
 OPT 4 **VP 1000 (4 pcs)** Vertical Profile Trolley
 OPT 5 **HP 1000 (4 pcs)** Horizontal Profile Trolley
 OPT 6 **PT 1000 (4 pcs)** Product Transportation Trolley
 OPT 8 **WAS 1000 (2 pcs)** Window Assembly Station
 OPT 9 **PWB 4100** Tilting Window Assembly Work Bench
 OPT 10 **GT 1000 (2 pcs)** Gasket Trolley
 OPT 11 **DT 1000 (2 pcs)** Door Trolley
-
- OPT 13 **SA 251** Window Buffer Station
-
- OPT 14 **SM 201** Single Head Reinforcement Steel Screwdriver
 OPT 15 **SM 206** Fully Automatic Double Head Reinforcement Steel Screwdriver
 OPT 20 **SM 201 SD** Double Head Reinforcement Steel Screwdriver and Montage Drilling
-
- OPT 18 **NSM 352** Sash Assembly Station
 OPT 19 **NSM 353** Sash Assembly Station
 OPT 21 **WGM 202** Window Gasket Milling Machine
 OPT 22 **MCA 801** Automatic Mullion Connector Assembly Machine

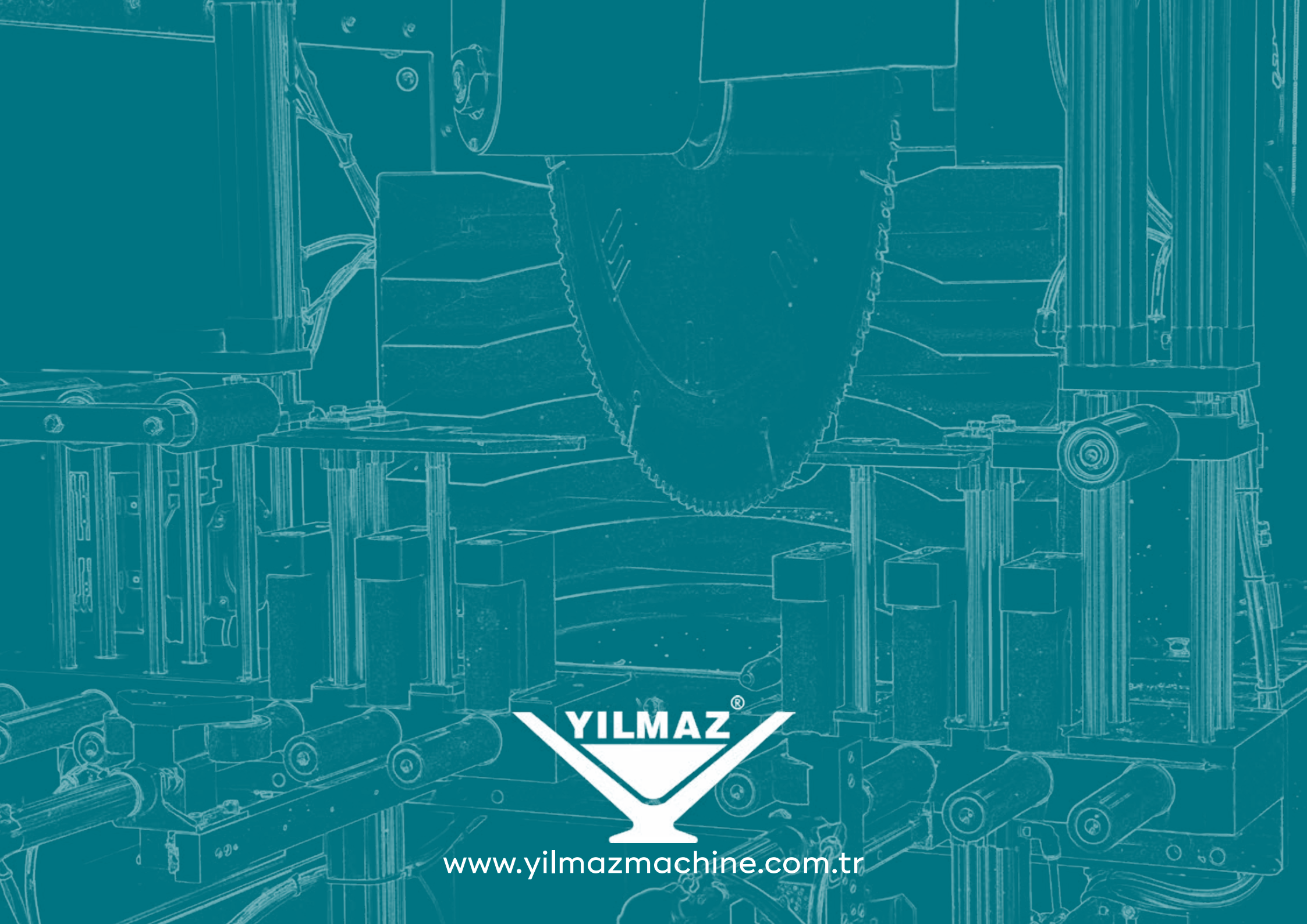

www.yilmazmachine.com.tr